



THE PHILIPPINE CRAFTSMAN

MARCH, 1913

A MAGAZINE PUBLISHED
AT MANILA BY THE BUREAU
OF EDUCATION DEVOTED TO THE
ADVANCEMENT OF INDUSTRIAL
INSTRUCTION IN THE PUBLIC
SCHOOLS OF THE PHILIPPINES

VOL. I

NO. 8



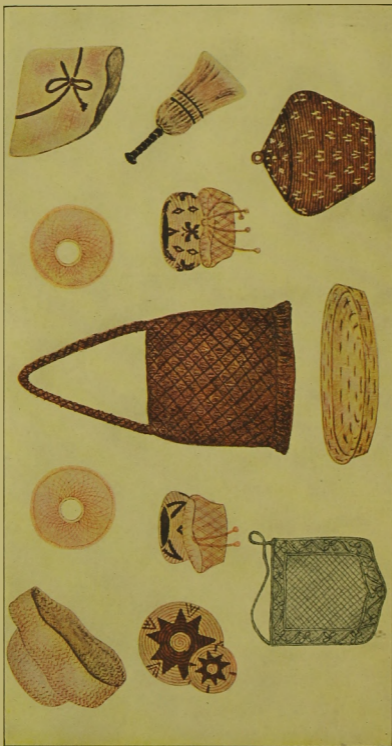

SPECIAL ABACA EXHIBIT.

The Philippine Craftsman

VOL. I

MANILA, MARCH, 1913

No. 9

EDITORIAL STAFF

Editor-in-Chief.—FRANK R. WHITE, Director of Education.

Associate Editors.—FRANK L. CRONE, Assistant Director of Education; CHARLES H. MAGEE, Second Assistant Director of Education.

Managing Editor.—JOHN S. POTTER, Chief, Division of Publications and Industrial Information, Bureau of Education.

Contributing Editors.—W. W. MARQUARDT, Superintendent, Philippine School of Arts and Trades, Manila; HUGO H. MILLER, Head of the Industrial Information Department, Bureau of Education; LUTHER PARKER, Industrial Inspector, Bureau of Education; JOHN D. DEHUFF, Superintendent of City Schools, Manila; WM. F. MONTAVON, Division Superintendent of Schools for *Tayabas*; LEROY R. SAWYER, Industrial Inspector, Bureau of Education.

CONTENTS

	Page
The 1913 Industrial Exhibition of the Public Schools of the Philippines, Manila, February 1-9. By Luther Parker, North H. Foreman, Theodore Muller, O. C. Hansen, and Leroy R. Sawyer	631
Operating a Trade School as a Commercial Shop. By Paul F. Whitacre	666
Felling, Sawing, and Seasoning Timber. By E. E. Schneider	671
Annual Convention of Division Superintendents	689
Two Methods of Stripping Abaca. By Hammon H. Buck	693
Vocational Guidance—Marine Officers. By Frank P. Helm and Henry B. McCoy	695
Editorial and Official	699
Industrial Notes	711

The Philippine Craftsman is published by the Bureau of Education at Manila, P. I., monthly during nine months of the school year from June to March. The subscription price is P3.00 per year or P0.60 per copy, postage prepaid in the Philippines, the United States, and other countries under the same postal regulations; to countries not counted in this classification, P4.00 per year or P0.70 per copy. (P1.00 equals \$0.60.) Address correspondence and make subscriptions payable to the Director of Education, Manila, P. I.

Entered at the Manila post-office as second-class matter.

The present system must change if it is to meet the needs of the future. My plea is for a tremendous expansion of the vocational, industrial, and technical side of education, so that the children shall not leave school with a broad smattering only of all kinds of knowledge, but so that they shall be prepared to do the work of the future; so that they shall be able to do every form of work well in the shop, in the factory, and in the home.

Theodore Roosevelt.

The Philippine Craftsman

VOL. 1

MARCH, 1913.

No. 9.

THE 1913 INDUSTRIAL EXHIBITION OF THE PUBLIC SCHOOLS OF THE PHILIPPINES, MANILA, FEBRUARY 1-9.

By LUTHER PARKER, NORTH H. FOREMAN, THEODORE MULLER, O. C. HANSEN, and LEROY R. SAWYER.

[Photos by the Bureau of Education. Reprints authorized giving credit to the Bureau of Education, Manila.]

PAST EXHIBITIONS.

IN ORDER to appreciate fully the significance of the exhibition of industrial work recently held it will be necessary to give a brief reminiscent survey of the movement to introduce practical handwork in the primary schools of these Islands during the decade just past, during which there has been worked out by an able body of enthusiastic teachers a successful plan of industrial courses untrammelled by the traditions prevailing in many educational systems.

The first exhibition of industrial work was that of the St. Louis Exposition in 1903 in which 37 divisions or provinces were represented, 2,494 articles being exhibited. The following short list of articles will give an idea of the kind of industrial instruction being given at that early date in schools established under American rule for two years or less and before peace had been fully established in all school divisions: Artificial flowers and fruit baskets; bamboo utensils; buri work; models of boats; toys; clay models; common crochet; drawn work; dyed articles; embroidery on piña cloth; fabrics; hats; mats; models of houses; agricultural, spinning, and weaving implements; metal work; instruments; needlework; fish nets; pottery; preserved fruits; samples of paper folding, cutting, and weaving; embroidered picture frames; pith work; seed work; silk cloth; sloyd models; shell work; screens; traps; woodwork; weapons. Much of the above work was of ethnological interest only and was secured later for museum purposes.

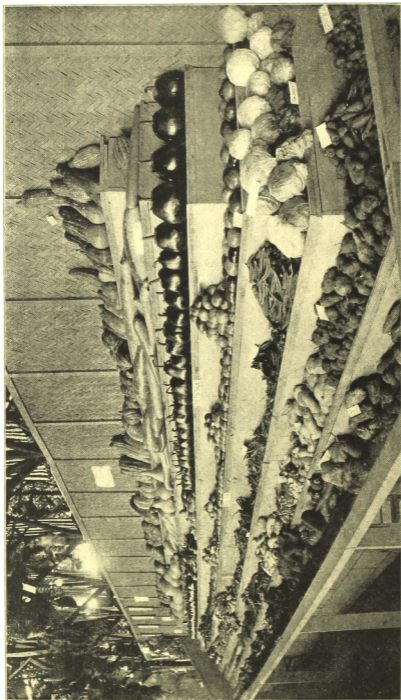

Plate I. View of the general vegetable display.

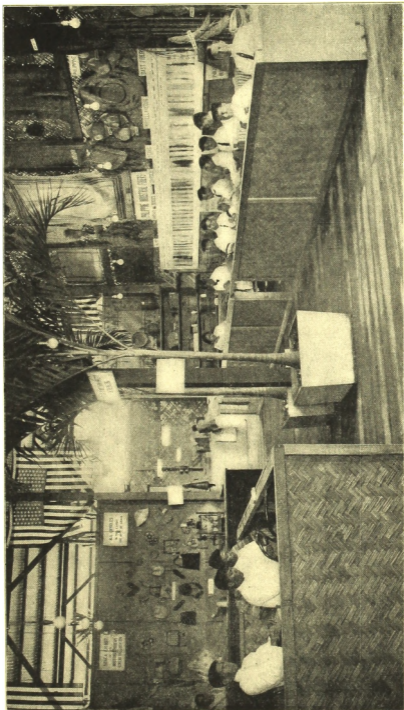

Plate II. Section of the Industrial Museum exhibit.

The careful student of industrial work as it is now being done will recognize in the above list of articles several things that were inherited with the teachers trained under the Spanish régime, such as shellwork, embroidered picture frames, crocheted table covers and chair-back covers, piña embroidery, and artificial flowers and fruits. The influence of the new American teacher can be seen in the various models of implements, the bamboo utensils, the paper-cutting exercises, and the sloyd models. The purely native products, such as hats, mats, traps, weapons, and baskets were merely copies of things in daily use and comprised the class of articles that were of ethnological value. To this class of articles the schools have now returned at the end of ten years' experimentation for something truly typical of the Philippines in workmanship and design. This is especially true in basketry and loom-woven fabrics.

In the development of a consistent and well-organized plan of school industrial work there should be noted the elimination of such articles as toys, models, paper work, and other nonproductive exercises from the course of study and the substitution of plain and fancy needlework, cooking, basketry, woodwork, and gardening. Credit should be given to the Spanish Government for carrying on some industrial work in private and public schools before the American occupation. The church records of Arayat, Pampanga, contain recommendations made in 1784 and 1790 to the padre from the celebrated archbishop of Manila, Don Basilio Sancho de Sta. Justa y Rufina that weaving, mat making and other handicrafts be taught in the Arayat schools. The Augustinians were teaching handwork in their school at Lubao, Pampanga, about the middle of the eighteenth century and trade schools were fitted up in Manila, Iloilo, and Bacolor before 1896.

The next formal display of industrial work after the St. Louis Exposition was held in Manila in October, 1907. The schools had been forging ahead since 1903 and the results of this exhibition were a revelation to the public. All school divisions were represented except Bohol, Cagayan, Isabela, and Nueva Vizcaya, while the city schools of Manila held a separate exhibit at Cuartel Meisic. Approximately 10,000 pieces were exhibited of which 1,080 pieces were sold for ₱425.94, an average of 40 centavos apiece. This was the beginning of the sales exhibits by the Bureau of Education and was the result of the vital interest taken by the public in the articles made by the pupils.

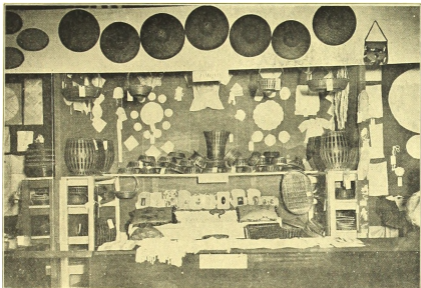

Plate III. The Zambales exhibit.



Plate IV. A display of industrial work from Bohol.

The idea of a sales exhibit was new to the teachers, but after consideration and discussion it was decided that no better way could be devised for testing the practicality of the industrial instruction than by offering the best results of the year's work for sale each year in Manila where the judgment of the cosmopolitan buying public would be determinative of the wisdom of the lines of work being pursued in the schools of the Archipelago.

The sales exhibit became a feature of the yearly exhibit in Manila and the wisdom of submitting the work of the schools to the crucial test of salability has been fully justified. The pupils who furnish the material and do the work receive the profit and are encouraged to continue as producers after leaving school. Most of the materials used are native to the Islands and in many cases are unused products of a tropical vegetation that would otherwise rot in the forest. The search for suitable industrial fibers has familiarized the present generation with the resources of the country as no amount of theoretical book-work could ever have done. The long, idle hours that formerly hung heavily on the hands of an agricultural population can now be turned to profit, thereby assisting in raising the standard of living and adding to the per capita wealth of the country. The age of machinery is yet to come in the Philippines. All grades of society are represented in the schools, the great majority of the children being from homes where the grade of culture makes the handicrafts as yet the logical outlet for the energy of the people.

The third exhibition of the work of the public schools was held in conjunction with the Philippine Carnival in Manila, February 27 to March 7, 1908. All divisions were represented except Albay, Cagayan, Capiz, Isabela, Nueva Vizcaya, Oriental Negros, Sorsogon, and Surigao. No record was kept of the number of articles exhibited but the financial report shows the receipt of ₱860.72 for articles sold.

The fourth exhibition of school products took place in connection with the 1909 carnival, but as each school division exhibited as a part of the provincial exhibits no data are available as to the amount or value of these products. The fifth exhibition was held at the 1910 carnival and all divisions were represented except Albay, Cagayan, Isabela, and Nueva Vizcaya. Exact records were kept of this and succeeding exhibitions and are available for statistical studies.

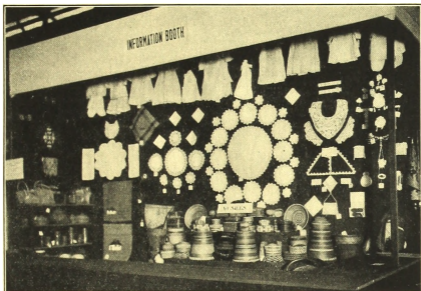

Plate V. Information booth of the Bureau of Education containing articles selected for the various division exhibits.



Plate VI. The Albay exhibit of Irish crochet.

A comparative table for the exhibits of 1910, 1911, 1912, and 1913 follows:

	1910	1911	1912	1913
Number of units exhibited	6,750	9,760	16,362	23,386
Number of units sold	2,648	5,564	13,349	17,464
Percentage of exhibit sold	35	44	75	70
Value of exhibit	P10,428.86	P18,964.62	P34,418.68	P57,183.21
Value sold	3,707.28	8,410.17	25,777.08	40,113.53
Average unit value of exhibit	1.54	1.94	2.10	2.45

THE 1913 EXHIBITION.

The most salient characteristics of this year's display of industrial work were the noticeable improvement in quality of



Plate VII. Display of Philippine industrial fibers.

work throughout the schools of the Archipelago, the prosecution of the industrial work in nearly all schools of Grade III and above, the standardization of the principal lines of handwork, the general extension of gardening and the conscious effort in many schools to develop a type of handicraft distinctly Philippine in material, form, and decoration.

The use of indigenous raw materials for industrial work in the schools will have a far-reaching effect upon the economic development of the country and the selection of designs distinctively characteristic of Malaysian art will give the handwork of the Philippines a place unique in the world of crafts. Refer-

ence to the statistical table above given shows that 70 per cent of this year's exhibit sold as against 75 per cent in 1912. This was due to two reasons: the increased representation of industrial work from the lower grades and the oversupply of a few lines of articles that have been standardized and are being turned out in large quantities in many provinces. Such articles are wastebaskets, work baskets, lunch baskets with round covers and rigid handles, market baskets of the Polangui type, embroidered handkerchiefs, ordinary bobbin lace, and plain doilies.

Some of the types of baskets that sold well last year were not in demand this season. However, one of these, the Polangui lunch basket with round cover and collapsible handle, is reported as being in demand in the United States. In general, it may be said that all good work with well-prepared materials and listed at a reasonable price will sell at the yearly exhibit and that a large proportion of the articles returned unsold are faulty in some way, either in workmanship, design, materials or price.



Plate IX. A well-known Philippine basket material.



Plate VIII. Young rattan plants.

SOURCES AND UTILIZATION OF INDUSTRIAL MATERIALS.

A statement of the principal lines of industrial work being carried on in the schools will no doubt be of interest to those unfamiliar with present plans and policies. The boys are taught gardening and farming, woodwork, bamboo and rattan work, basketry and hand weaving in the minor industries, while the girls receive training in cooking, plain sewing, lace making, embroidery, slipper making, loom weaving, crocheting, tatting, mat weaving, hat weaving, and other similar industries.

Of as much interest would be the naming of some of the most useful fiber plants and the enumeration of articles made from them.

The bamboo and buri palm compete for first place as the principal industrial fiber plant for



Plate X. One of the best Philippine hat and mat materials.

local use. From the bamboo can be made almost anything used by the farmer except cloth and with patience a mat can be woven almost fine enough to be used for this purpose. Here are a few of the things in daily use that are made from bamboo: Houses, fences, sleeping mats, hats, farming implements, fish traps, traps for wild animals, rafts, cooking utensils, weapons, irrigation pipes, musical instruments, baskets, cigarette cases, picture frames, boxes, and furniture. The young bamboo shoots can be eaten and some varieties of bamboo contain drinking water.

From the trunk of the buri palm a house can be built, the roof can be made of the leaves, cloth can be woven for primitive clothes, for sails of boats and sleeping mats, the sap can be



Plate XI. Seven varieties of tugue, a native root surpassing the Irish potato as a food.

made into either a drink or sugar, and the heart of the palm yields a substitute for flour. Three kinds of hats can be made from the leaf and various articles from the raffia stripped from the leaf, such as coiled baskets, macramé hand bags, porch and carriage cushions, and several grades of matting.

The next plant of great economic importance for local use and foreign export is abaca or Manila hemp from which cordage has been made for centuries. To the eye of the unimaginative individual a clump of abaca plants is only a clump of abaca and nothing more, but to the industrial teacher gifted with insight the clump disappears and is replaced by a carload of rope, hats, mats, slippers, baskets, cloth, and all the various articles that the ingenuity of clever workers can turn out from the fibers of

this marvelous plant. Other plants worth mentioning are the coconut palm, sugar palm, sabutuan, pandan, banban, ferns, the tree fern, small palms, maguey, air roots,

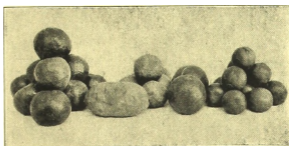

Plate XII. Five varieties of citrus fruits common to the Philippines.

grasses, sedges, and pineapple. From each of these plants have been made various articles of commercial value during the past year and no doubt new uses will be discovered during the coming year since this fascinating study of the uses of native materials has been taken up so enthusiastically by a large number of intelligent people who are charmed by the novelty of this work in the educational world.

The Bureau of Education has an industrial supervisor in nearly every division who is charged with the development and extension of industrial work in his respective territory under the direct supervision of the division superintendent of schools. One of the most notable results of such work during the past year has been the study of the relation between the raw material supply of a district and the industrial work selected for the schools therein. Scarcity of materials in certain sections has led to the investigation of the suitability of roots for basketry and good results have been secured with the roots of the bamboo, coconut palm, and some other common plants for weavers in basket bottoms. It is this ingenuity of the teachers and pupils in finding new materials and new uses for old materials that makes the work of increasing economic importance to the country.

The search for types of baskets of weaves and designs native

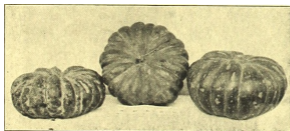

Plate XIII. Squashes.

to the country has been rewarded with the finding of several pleasing and distinctive types, especially in southern Panay, where the people have faithfully preserved

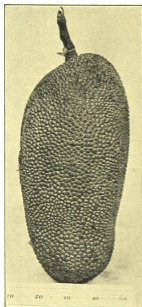

Plate XIV. Jack fruit.

through four centuries the handwork in basketry and weaving of their Bornean ancestors. Their primitive hand loom, or "sidad," is yet used to weave buri raffia cloth which served for clothes and sails. The systematic study of Malaysian design being carried on by the Bureau of Education is bearing fruit in better and more fitting designs in basketry as seen in the coiled baskets from several of the more progressive provinces. The use of the natural colors of the materials in basketry opens up great possibilities in artistic handicraft. At the same time the subject of dyeing has been given much laboratory study this past year and this will aid workers in the field materially during the coming year.

Some good discoveries in the use of ferns have been made. Worthy of special note is the use made of kilog for basketry in Laguna Province. The trunk of the fern tree deserves to be studied both for the production of artistic novelties and for the beautiful natural designs of the fiber arrangement. The buri-rib baskets of Cebu are indicative of what can be done with a material little used heretofore. The coconut palm has not yet come into its own, but judging from the coir mat, Bohol "mutt," and coconut shell guitars and button boxes already exhibited, this material would seem to be worthy of more study by industrial supervisors in coconut palm districts.

The preserving of native fruits and the making of jams and jellies are being given more attention throughout the Archipelago and when the question of prices has been satisfactorily solved there will no doubt be a great demand



Plate XV. Five kinds of coconuts. The one in the middle is the largest ever shown in Manila.

for many of the delicious fruits of the Philippines. Canned fruits were exhibited this year by six provinces and sold well where properly packed, displayed, and priced.

THE INDUSTRIAL MUSEUM SECTION.

In this section there was to be seen an interesting and complete general display of growing industrial fiber plants, of fiber materials and of finished products. A special feature was an exhibit showing what work had so far been done with abaca fibers. In both the general and special displays, workers from the Philippine Normal School and city schools of Manila showed the preparation of industrial materials and the fabrication of articles.

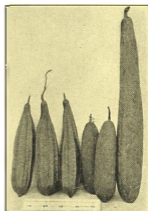

Plate XVI. Pabalas.

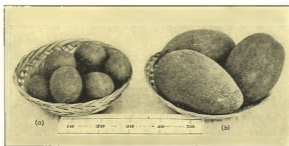

Plate XVII. (a) Ordinary chicos; (b) Chilo mamey found only in the uplands of Cerillo.

In one portion of this space the most important fiber plants were shown. This exhibit feature was considered very instructive by industrial workers and all interested in Philippine industrial activities.

It also proved very attractive to the general public as the artistic side of the display had been carefully considered. Large palms and other plants formed the background of the exhibit and in front was a small pond in which nipa and sedges were growing. The palms were well represented by young buri palms, sugar palms, fishtail palms, tipontipon and several species of rattan. The collection of pandans was very complete and included sabutan, pandan of Majayjay, karagumoy, and the common seashore pandan. The cultivated vetiver which yields fragrant roots and the spiny bamboo, both

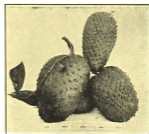

Plate XVIII. Sourson or guayabana.

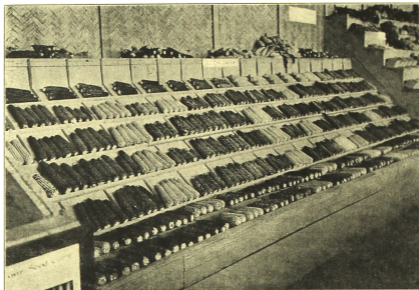

Plate XIX. Final corn exhibit of the 1912 corn campaign of the Bureau of Education.

as seedling and when ready to be cut down into hat straw, were shown. Kilog, the fern used successfully in Laguna Province, and the common nito fern planted among rocks, were the objects of particular attention. Placards attached to the various plants gave both common and scientific names. Tambó, banban, irao, and various species of vines yielding air roots completed the exhibit of Philippine fiber plants.

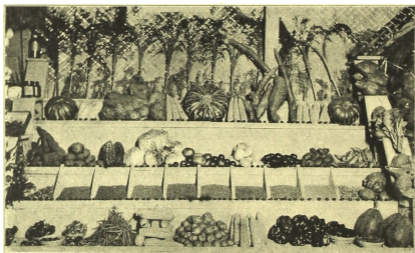

Plate XX. Indang, Cavite, farm school exhibit.



Plate XXI. Filipino young women in charge of the service of noon meals held in connection with the industrial exhibition.

Adjoining the exhibit of growing plants were booths showing the preparation of industrial materials, fabrication of articles, and the finished products. For two hours every morning, afternoon, and evening, students from the Philippine Normal School were occupied in the preparation of the various industrial ma-



Plate XXII. The winning exhibits of the 1912 corn campaign.



Plate XXIII. Hand stone mill and native meal sifters.

materials and made baskets, hats, mats, handbags, slippers, and other articles. The idea underlying the whole fiber exhibit was to demonstrate all the various steps from the growing plant to the finished product.

In the booth for the preparation of industrial fibers, the following materials in the raw state were displayed: buri straw, nito, tipon-tipon, sabutan, kilog, pamago, pandan of Majayjay, air roots, bamboo, banban, buri raffia, sugar palm, buntal, and balangot.

In the booth for the preparation of industrial fibers, the following materials in the raw state were displayed: buri straw, nito, tipon-tipon, sabutan, kilog, pamago, pandan of Majayjay, air roots, bamboo, banban, buri raffia, sugar palm, buntal, and balangot.

In the space set aside for the fabrication of articles great interest was evinced in the chart over 20 ft. long showing samples of all the principal Philippine industrial fibers. Under the buri palm, for example, were listed and shown samples of buri straw, buri raffia, calasiao straw, and buntal; under bamboo, the stem, straw, and inner sheath were exhibited. All palms, pandans, ferns, grasses, sedges, and other fibers were grouped together, and under each individual plant appeared all industrial materials derived from it. On the wall space above the chart were displayed for exhibit purposes, mats, mattings, cushions, and hats.

In the space of the industrial museum reserved for the exhibit devoted to abaca there were arranged on shelves various grades of abaca fibers, tied abaca, and abaca braid; also abaca hats, numerous samples of abaca sinamay and pinolpog and various kinds of slippers. On the walls were displayed the latest samples of abaca braid hats woven in the sawale style, abaca handbags (macramé weave or with Hardanger embroidery), lamp shades, hand satchels, belts and trays of abaca lupis. An abaca braiding machine illustrating the manufacture of braid and a simple wheel showing the making of abaca cord attracted large crowds. In the abaca work booth, teachers from the city schools of Manila and students from the Philippine Normal School demonstrated the actual fabrication of various abaca articles. Dyed abaca illustrated the most satisfactory colors as yet produced on abaca.

The results of this museum exhibit may be summarized as follows:

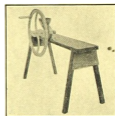

Plate XXIV. Improved hand corn mill, introduced during the 1912 corn campaign.

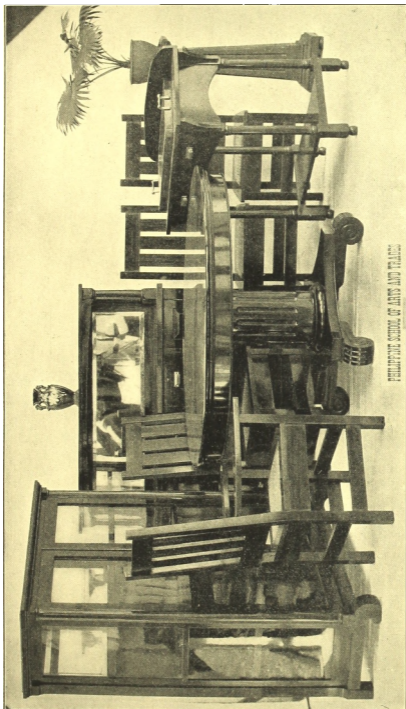

Plate XXV. Dining-room set, Philippine School of Arts and Trades.

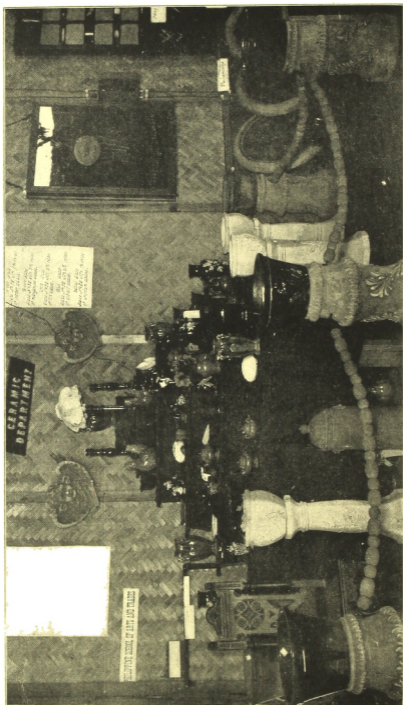

Plate XXVI. Ceramic exhibit, Philippine School of Arts and Trades.

1. It gave the public a comprehensive view of the fiber plants and fiber materials available for fabrication of articles in the Philippines.

2. It showed how industrial materials are prepared and utilized.

3. It brought to the attention of the industrial workers plants that had heretofore been unknown to them.

4. It showed the many different ways in which abaca fiber can be utilized.

5. It brought prominently before the people the making of abaca braid, an industry of importance in Japan but not in the Philippines which furnish the Japanese with the raw materials.

6. The exhibit proved to be of particular interest to dealers in furniture, braid, agents for machinery, and hat weavers.

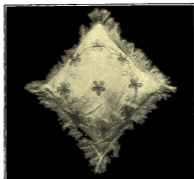

Plate XXVII. Pinolpop cushion embroidered with abaca.



Plate XXVIII. Covered collar and work baskets of various materials.

THE AGRICULTURAL SECTION.

An area comprising approximately one-eighth of the entire space of the exhibition building was used for the display of agricultural products from the farm schools and from school and home gardens. In this section were shown the five distinct features empha-

sizing the agricultural education given in Philippine public schools.

The vegetable exhibit contained not only a complete collection of all vegetables grown in the school and home gardens but also an excellent assortment of yams and native roots. Among the latter were eight varieties of tugue, four of ubi, cassava, arrow-



Plate XXIX. Buntal baskets from the Philippine Normal School.



Plate XXX. Three good wastebaskets.

potatoes, carrots, and radishes. The exhibit of tomatoes comprised some ten varieties and was to many people the most interesting feature. The eggplant exhibit was the largest and best ever placed in Manila, the twelve varieties including native, New York purple, and black beauty. Other noticeable products were the eighteen varieties of peppers, many of these large bell peppers; a large number of legumes; and



Plate XXXII. Zambales bamboo baskets.

root, ginger, gabi, and many kinds of sweet potatoes. Along with the native roots were shown roots recently introduced into the Philippines, such as beets, turnips,



Plate XXXI. Types of hand satchels.

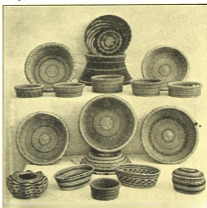

Plate XXXIII. Varieties of workbaskets.

twelve varieties of squashes and gourds of the finest quality, eight of which were edible gourds common to the Philippines. In addition to the general display of agricultural

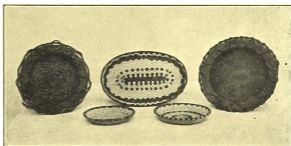

Plate XXXIV. A few trays.



Plate XXXV. Tigbaun jewel and button boxes.

products, a series of individual booths contained exhibits from the various farm schools. The following were represented:

1. The Batac Farm School located at Batac, Ilocos Norte, had a representative exhibit, the principal features of which were fine peppers and a complete display of the processes of silk production. For the past four years silk culture has been given considerable emphasis at this school.

2. From the Indang Farm School, Cavite, there was an excellent showing of beets and green peas.



Plate XXXVI. Something new in collar boxes.



Plate XXXVII. A Philippine clothes hamper.

3. The Central Luzon Agricultural School located at Muñoz, Nueva Ecija, is the largest agricultural project conducted by the Bureau of Education and controls a large area of land in a section of the country which is rapidly being taken up by settlers. This school exhibited a fine collection of grains. A glass case containing 57 insect pests common to that locality was an interesting feature.

4. From the Iba Farm School, Zambales, there was an exhibit of farm crops which showed what is actually being done at the school. Small bottles containing certain insects destructive to farm crops, which had been borrowed from the laboratory and museum collection of the school, were displayed.

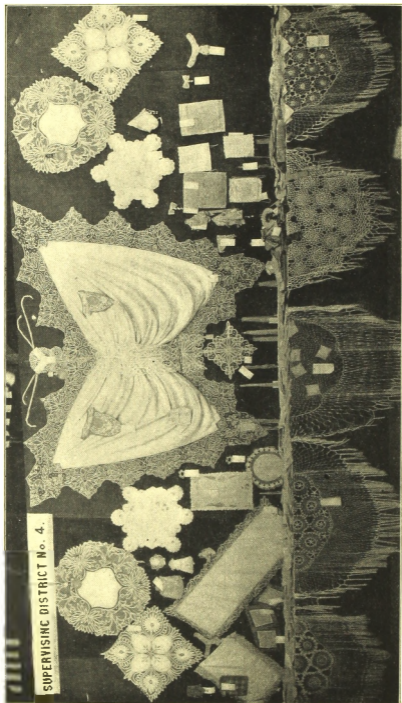

Plate XXXVIII. Supervising district No. 4. city schools. Manila.

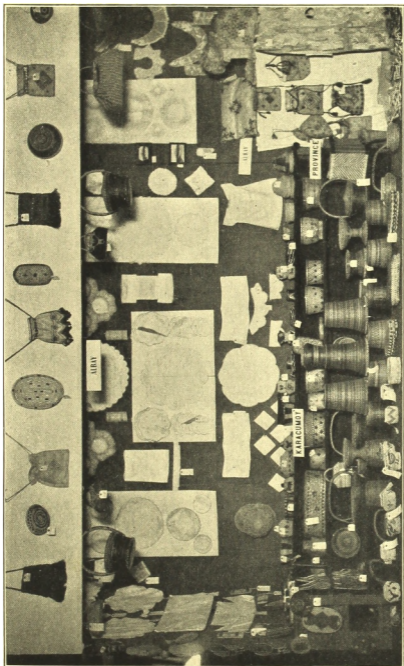

Plate XXXIX. Exhibit in the Athay booth.

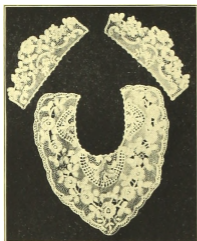

Plate XL. Point collar and cuffs.

5. The Bukidnon exhibit consisted of products from the agricultural and settlement farm schools in the province of Agusan. Here were to be seen the kinds of food which are being grown on the many settlement farms by Bukidnon and Manobo children. These farms are located in the interior of Mindanao and are devoted to teaching actual food production. This exhibit was particularly interesting because its transportation required five days by pack animals and six days by boat before reaching Manila.

6. The Manila city schools and the Philippine Normal School had booths which were kept well supplied with fresh vegetables throughout the exhibition. The large variety of excellent vegetables placed on display indicated that gardening is receiving proper emphasis in all these schools and that the teachers are being trained to give instruction in industrial as well as in academic subjects.

7. A comprehensive exhibit of seedlings came from the Tanauan intermediate school. This nursery is one of the many of the same kind which are being established throughout the provinces for the selection and distribution of desirable fruits.

Another noticeable feature was the first fruit exhibit ever held in Manila. Ninety varieties of native fruits from every province in the Philippines and practically every variety of fruit which is ripe during the months of February were shown.

A display of corn submitted in the final exhibit for the corn growing contest No. 2 of the 1912 corn campaign included 135 entries. This exhibit represented all school divisions with the exception of Antique, Leyte, Capiz, Samar, Isabela, Misamis, Surigao, Tayabas, Mountain, Nueva Vizcaya, and Cagayan. The corn was judged by a committee composed of Mr. H. T. Edwards, Assistant to the Director of Agriculture, Mr. Harold Pitt of the Manila Merchants' Association, and Mr. Teodoro R. Yangco, a Manila merchant, and was rated by the same kind of score cards used in the 1912 corn campaign.



Plate XLI. Samples of filet crochet on towels.

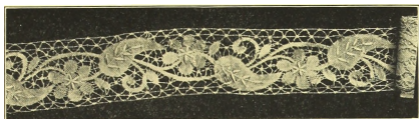

Plate XLII. A handsome pattern of bobbin lace.

By a compilation of the scores the following boys were declared winners:

First. Julian Enriquez, age 13, of Danao, Cebu.

Second. Catalino Alger, age 17, of Calamba, Laguna.

Third. Francisco Duerme, age 14, of Iba, Zambales.

Features relative to the growing of corn were shown in booths properly placarded. The comparative production and value of corn were stated and through a series of exhibits were demonstrated (*a*) selection of seed corn, (*b*) testing the seed corn, (*c*) preparation of the soil, (*d*) planting of corn, (*e*) cultivation of corn, (*f*) harvesting of corn, (*g*) corn implements, and (*h*) corn products. Ten young men representing nine provinces were brought in and placed in charge of this work. Explanations relative to the proper growing of corn, its production and use in the Philippines were given.

In a series of demonstrations of corn as a human food, dishes prepared from corn were served to visitors without charge and

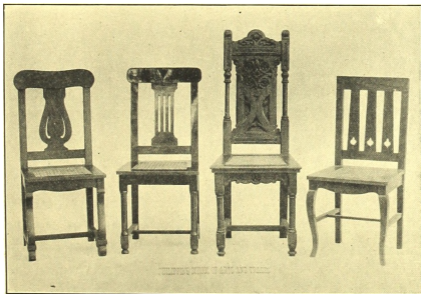

Plate XLIII. Types of chairs, Philippine School of Arts and Trades.

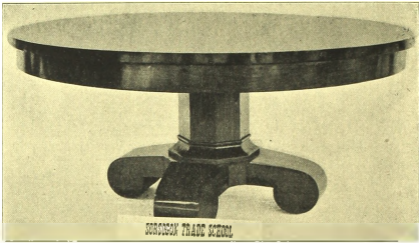

Plate XLIV. Dining table with one-piece top, 7 feet in diameter. Value, P250.

corn recipes distributed. The popularity of this feature of the corn demonstration can be best shown by the number of services of food given out. Although foods were served but one and a half hours each day during the ten days of the exhibition 15,000 services of corn foods were made. The following recipes were demonstrated and distributed in pamphlet form to the public: (1) Corn and tomato, (2) hominy, (3) hoe cake, (4) mush and milk, (5) fried hominy, (6) succotash, (7) stewed corn, (8) fried mush, (9) corn pone, (10) hot cakes, (11) corn coffee, and (12)



Plate XLV. Office desk, Laguna Trade School.



Plate XLVI. Some types of wastebaskets.

"tiste." The preparation of the corn foods and their serving were done by eleven Filipino young women who were brought in from the provinces for this purpose. These young women represented eight different provinces and were able throughout the day to explain any feature pertaining to the use of corn.

The success and value of the agricultural section are best shown by the number of people who visited it and were anxious to secure seeds of the many excellent plants displayed. As indicative of the large number of visitors a record kept by the representative of the Central Luzon Agricultural School booth discloses the fact

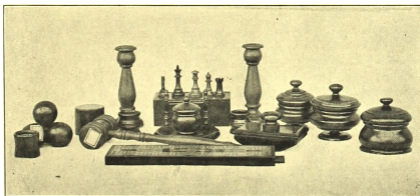

Plate XLVII. Turned work, Philippine School of Arts and Trades.



Plate XLVIII. A popular model of siesta chair.

of ₱57,183.24. Many tags represented sets of furniture, embroidery work, handkerchiefs, or baskets. Lunch sales by the Philippine Normal School and the Manila schools amounted to ₱823.49 additional, making a grand total of ₱58,006.73. Total sales of manufactured articles (not including lunches) were indicated by 17,464 tags averaging ₱2.30 in value, or a total of ₱40,113.53; 5,825 articles were not sold, averaging ₱2.93 per tag, or a total of ₱17,069.71.

The total of 17,464 articles covered by these 1913 sales compared with the 13,349 articles sold in 1912 shows a decided increase in the average value of the articles sold, being ₱2.30 compared with ₱1.93. This difference does not represent an actual increase in prices but rather a higher class of workmanship and a more pretentious line of articles, such as magnificent sets of furniture, elegant Irish-crochet dresses and coats and complete sets of embroidered table linen and doilies. Prices were in reality lower than in previous years.

The table appearing on pages 664-665 shows in detail the comparative standing of the various provincial exhibits. Albay heads the list with a total of 997 articles valued at ₱2,763.65, all schools of the province being represented. In number of articles, Camarines is second with 952, and Capiz third with 777; in money value, Pangasinan is second with ₱2,650.57, and Sorsogon third with ₱2,605.95. Fifteen provinces showed a 100 per cent repre-

that during a period of three hours more than 300 different individuals had stopped at his booth and made inquiries concerning the products on exhibition and the work of his school.

SOME EXHIBITION STATISTICS.

The total number of articles on exhibit exceeded 25,000 and were covered by 23,305 tags averaging ₱2.45 in value, or a total

of ₱57,183.24. Many tags represented sets of furniture, embroidery work, handkerchiefs, or baskets. Lunch sales by the Philippine Normal School and the Manila schools amounted to ₱823.49 additional, making a grand total of ₱58,006.73. Total sales of manufactured articles (not including lunches) were indicated by 17,464 tags averaging ₱2.30 in value, or a total of ₱40,113.53; 5,825 articles were not sold, averaging ₱2.93 per tag, or a total of ₱17,069.71.

The total of 17,464 articles covered by these 1913 sales compared with the 13,349 articles sold in 1912 shows a decided increase in the average value of the articles sold, being ₱2.30 compared with ₱1.93. This difference does not represent an actual increase in prices but rather a higher class of workmanship and a more pretentious line of articles, such as magnificent sets of furniture, elegant Irish-crochet dresses and coats and complete sets of embroidered table linen and doilies. Prices were in reality lower than in previous years.

The table appearing on pages 664-665 shows in detail the comparative standing of the various provincial exhibits. Albay heads the list with a total of 997 articles valued at ₱2,763.65, all schools of the province being represented. In number of articles, Camarines is second with 952, and Capiz third with 777; in money value, Pangasinan is second with ₱2,650.57, and Sorsogon third with ₱2,605.95. Fifteen provinces showed a 100 per cent repre-

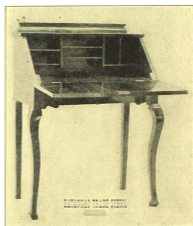

Plate XLIX. Lady's writing desk. Balangas Trade School.

sentation of the schools of the divisions.

In 1912, 13,349 articles were sold for ₱25,777.08 in competition with the exhibits of the provincial governments, but with the help of the large number of visitors attracted by the first Philippine exposition. This year, without competition and with a smaller number of visitors from outside of Manila, the sales amounted to ₱40,937.02. Of the total sales the provincial share was 9,886 articles valued at ₱19,549.60 in 1912 and 13,407 articles valued

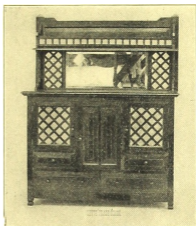

Plate L. Sideboard with shell panelwork, Leyte Trade School.



Plate LI. Philippine basketry.



Plate LII. Karagumoy and buri baskets of characteristic weaves.

at ₱31,405.86 in 1913. The balance of the sales was made by the Manila city schools, the Philippine Normal School, and the Philippine School of Arts and Trades.

PLANS FOR THE NEAR FUTURE.

An appropriation of ₱100,000 has been made by the Philippine Legislature for the purpose of holding an exposition in Manila in 1914. This will be the last possible exhibition held locally before the Panama-Pacific Exposition takes place in San Francisco, February 20 to December 4, 1915, and no doubt much of the 1914 exhibit will be acquired and forwarded to San Francisco. The Bureau of Education exhibit in Manila in 1914 will have to be prepared with this aim in view, and the question of a suitable line of industrial work for the coming school year is a vital one to all schools. As a basic principle, there should be no sacrifice of the training of the child for his life work in the preparation of an exhibit, but there is no good reason why the two can not be correlated.

The appropriateness of practical industrial work of any type should be determined by the demand—local and foreign—for the output of the homes after the training received in the schools. Primarily the purpose of this work is to raise the standard of living in the homes by teaching pupils how to make and use better things and secondarily to increase the per capita wealth by the



Plate LIII. A piano seat of attractive design.



SPECIAL ABACA EXHIBIT.

Abaca fiber is not only excellent for cordage, but also furnishes a good material for the fabrication of many handsome articles of commercial value.

transmutation of wasted sunlit hours into gold.

After supplying local demands for necessary articles of everyday use, the foreign market for articles of handicrafts of artistic merit should be considered. It is here that the Panama-Pacific Exposition comes in for consideration. The ordinary articles

for home use can be made in the lower grades of plain materials and will make an interesting museum exhibit. Articles of some artistic value and a varied line of novelties that will be appreciated by the

buying public for souvenirs of the Philippines can be made by the defter and better trained fingers of pupils of the upper grades.

A sales exhibit of Philippine handwork is needed at San Francisco to

awaken the United States to the capacity of the Filipinos for careful, painstaking handwork and no method has yet been devised that will so effectively interest the public in an exhibit as to allow the sale of articles admired and coveted. Every one buying an article of Philippine manufacture becomes vitally interested in the people and their progress, while a

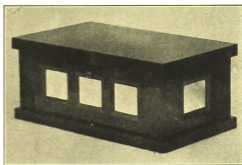

Plate LIV. Philippine ebony jewel box with inlaid squares of pearl.

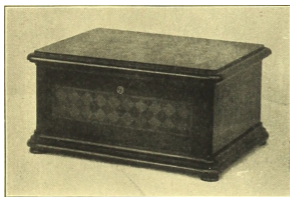

Plate LV. Inlaid jewel box.



Plate LVI. Some novelties in tree fern and bamboo.

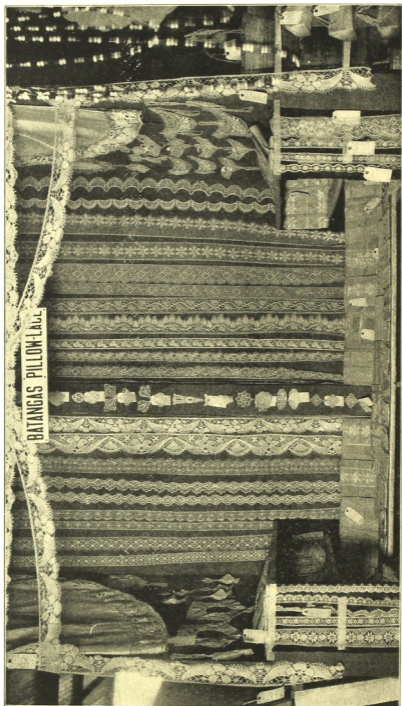

Plate LVII. Batangas pillow-lace exhibit.

visit to a museum containing the same articles would arouse but little interest.

There is still another side to a sales exhibit at the Panama-Pacific Exposition that should not be lost sight of by those interested in seeing the Philippines develop new industries and that is the getting in touch with the world's markets to determine the class of articles in demand. No better method could be devised than a working and sales exhibit in which representatives of commercial institutions could study the production of the articles in all its processes and note the class of labor to be dealt with and its relative efficiency.

The best study of division superintendents, industrial supervisors and teachers should be given this subject of representation at the Panama-Pacific Exposition and an early decision should be reached as to the special class of work to be done in each municipality, in addition to the regular basic courses at present in force.

The opportunity to show to a critical and appreciative public the results of a decade of practical industrial instruction in the public schools of the Philippine Islands may not occur again in the history of our country and for intelligent people to neglect this opportunity and not make the most of it would be inexcusable in the extreme.

Details of exhibits by provinces and schools, Bureau of Education Industrial Exhibition, 1913.

Provinces.	Exhibited.		Sold.		Returned.		Percent- age sold.		Due of total sent from provinces to—		Number of schools.		Rank of prov- ince.	
	Num- ber of arti- cles.	Value.	Num- ber of arti- cles.	Value.	Aver- age value.	Num- ber of arti- cles.	Value.	Aver- age value.	Per- cent- age.	Pupils.	Govern- ment.	Total.		Repre- sented.
Albay	597	₱2,763.85	965	₱2,656.40	₱2.66	32	₱98.25	₱6.53	93	₱576.79	₱2,186.96	25	25	
Antique	306	1,476.13	201	1,282.55	1.41	107	122.55	1.50	60	182.61	313.62	14	14	
Bataan	613	4,700.75	2,229	3,966.15	1.87	247	716.66	2.90	49	353.22	1,057.93	13	13	
Batangas	678	2,697.39	578	2,121.99	3.64	97	476.40	4.80	52	716.96	1,880.44	73	73	
Bohol	689	1,866.27	2,74	685	1.23	154	476.69	3.13	14	306.90	1,559.81	21	21	
Bulacan	569	1,235.61	496	497.65	1.23	154	476.69	3.13	49	185.64	1,050.81	21	21	
Cagayan	822	1,553.99	1,91	586	3.02	182	215.25	4.45	42	185.64	1,368.46	19	19	
Camarines	777	1,553.99	635	1,313.15	2.02	182	215.25	4.45	82	249.94	1,303.48	41	41	
Cebu	459	856.17	2,26	246	2.08	174	244.79	1.39	83	327.37	528.80	34	34	
Covite	611	1,354.86	2,23	463	2.08	174	443.57	2.55	54	315.77	640.40	16	16	
Ilocos Norte	480	1,427.96	2,23	463	2.08	174	443.57	2.55	62	317.72	1,024.14	16	16	
Ilocos Sur	457	810.88	1,77	379	2.08	101	562.50	5.57	61	463.04	974.92	68	68	
Iloilo	517	1,725.61	3,34	330	1.63	66	231.25	3.50	71	317.14	488.74	43	43	
Isabela	320	304.01	243	189.24	3.15	187	688.73	3.67	60	484.57	244.36	25	25	
Legazpi	529	1,502.90	2,89	302	0.78	218	134.77	1.15	56	517.10	985.80	13	13	
Leyte	469	1,123.00	2,41	371	1.54	89	170.29	2.09	84	333.09	793.91	11	11	
Mindoro	146	200.67	1,16	195.53	1.39	60	100.14	1.67	75	67.60	133.07	42	42	
Missamis	217	1,444.26	1,71	176	2.19	141	325.20	2.31	40	234.74	1,209.52	16	16	
Mountain	487	1,116.84	3,32	313	1.07	188	273.69	2.98	79	529.70	587.15	25	25	
Nueva Vizcaya	487	1,116.84	3,32	313	1.07	188	273.69	2.98	79	529.70	587.15	25	25	
Oriental Negros	546	1,375.95	2,32	392	0.87	154	163.75	3.10	100	25.95	81.90	26	26	
Palawan	329	949.56	1,99	256	1.25	64	153.65	2.43	59	557.99	817.97	12	12	
Pangasinan	329	949.56	1,99	256	1.25	64	153.65	2.43	76	390.62	335.63	25	25	
Pampanga	640	2,633.56	4,04	321	0.78	329	625.82	3.46	72	790.63	1,842.93	22	22	
Pangasinan	500	2,633.56	4,04	321	0.78	329	625.82	3.46	18	311.62	2,321.94	23	23	
Rizal	477	1,616.71	3,31	268	0.78	209	649.76	3.20	74	801.66	1,819.05	28	28	
Samar	529	1,151.48	2,21	464	2.09	56	222.26	3.97	81	443.35	707.53	17	17	
Sarangani	609	2,696.95	4,43	542	1.34	43	191.00	5.02	89	1,022.69	1,674.26	22	22	
Surigao	311	641.65	2,06	268	1.25	64	153.65	2.43	94	473.36	1,682.29	26	26	
Tarlac	622	1,110.82	1,75	464	2.63	141	325.20	2.31	71	411.79	707.65	11	11	
Tulagan	449	1,584.17	2,36	313	1.32	168	274.46	3.45	62	416.40	1,167.77	21	21	
Union	449	1,584.17	2,36	313	1.32	168	274.46	3.45	62	416.40	1,167.77	21	21	
Zambales	244	271.94	1,05	235	2.16	8	68.90	6.89	79	95.20	178.74	16	16	
Total	17,578	44,712.33	2,46	13,497	31,406.85	2.34	4,171	13,396.63	3.19	71	16,427.73	29,294.66	63	763

<i>Schools.</i>											
Manila	4,694	7,820.82	1.56	3,227	4,820.35	1.49	1,461	2,600.57	1.72	72	7,300.90
Trade School	518	3,650.63	7.39	391	2,778.37	7.11	127	1,062.26	8.25	73	3,650.63
Normal School	515	3,319.30	2.56	439	1,106.95	3.25	76	210.35	2.77	84	3,319.30
Total	23,305	57,188.24	2.45	17,464	40,113.65	2.90	5,325	17,093.71	2.93	70	31,577.66
<i>Lunch sales.</i>											
Normal School					319.42						
Manila					504.07						
Total receipts					40,987.02						

OPERATING A TRADE SCHOOL AS A COMMERCIAL SHOP.

PAUL F. WHITACRE, Principal, Pangasinan Trade School.

THE primary purpose of a trade school is to teach the students woodwork, iron work, and other industrial work, but it is also very desirable to have the records at the end of the year show a profit. The word profit is not used in its ordinary sense of excess of the selling price over the cost of articles manufactured, but refers to the excess of returns over all expenditures for supplies consumed, labor employed, and power expended, irrespective of teachers' salaries, which remain the same whether commercial work is done or not. After a school has demonstrated that money appropriated for its maintenance and support has not been spent wholly upon exercise work of debatable value, but that a fair rate of interest is being returned through the manufacture and sale of commercial articles, provincial officials will make appropriations sufficiently large to meet all necessary demands. Such a profit tends also to insure the moral support of provincial officials.

The real purpose of a trade school is to teach boys trades. If this teaching is done in a school which never shows a profit it is evident that the students fail to get an important part of their training—the training which prepares them to manufacture articles for prices comparing favorably with current market prices and at the same time yielding a reasonable gain.

Contract work during the overtime periods is the most satisfactory way of getting out good work, and a great deal of it, in a hurry. When students learn that they are to receive a certain amount of money as soon as a piece of work is finished, they will put in more time and work faster than if they were working on time wages and receiving pay for about one hour of overtime a day. The program, if possible, should be so arranged that all school work may be finished by noon, leaving the whole afternoon as overtime for commercial work. The rate of pay allowed a student for a piece of work should be the same that a local carpenter would receive for doing the same grade of work. A Grade V student and a Grade VII student should get the same pay for like jobs, because it will take the student in Grade V

longer to finish his work than it will take the student in Grade VII, and in this way the higher grade students will earn more than the beginners. All contract work should be carefully inspected, and if the quality of workmanship does not come up to the standard it should not be paid for. The rejection of all poorly made articles causes students to do good, careful work and keeps them from turning in anything that is shoddy in respect to workmanship or materials.

Time work in certain cases is more advantageous than piece work. A carpentry job requiring very fine and careful work should be done on a time basis rather than on a piece basis. Time work in polishing has a tendency to increase the price of the articles, but the prospective buyer would rather pay a little more and get a well polished and nicely finished article than to have it only half done and that half not well done. Polishing can not be hurried, and if a student tries to do so, the probability is that the articles will have to be re-sand-papered with a resulting waste of labor and materials and an encroachment on the profits of the school.

Under-lac may be substituted for shellac if a cheap polish is desired. If this is rubbed in like shellac, it will give a fairly good, quick polish. Sandpapering in all polishing is a very important factor. After the piece has been thoroughly scraped by a cabinet scraper it should be sandpapered until it is perfectly smooth. The piece should shine before the filler is applied.

When time workers and piece workers labor side by side there is a strong tendency to waste time. All jobs which must of necessity be done by time work should be done during the regular shopwork periods, so as to leave the overtime periods for piece work exclusively.

Labor performed by the students away from the school, such as repairing houses, is more satisfactory to the school if done on time work, on account of the unlooked for things which almost always occur in the course of the work.

Entering trade school students who have had woodwork in the municipal shops or the manual training shops in the intermediate schools can usually be started on small pieces which find a ready sale. This will save the expense of lumber consumed in the so-called practice exercises. The joints and joining required in the making of picture frames, screens, taborets, and other simple pieces are the same as those made in the prescribed woodworking exercises. In such a procedure the students may not require certain kinds of joints, but they learn to make the necessary

joints so well that they will have no difficulty in constructing new kinds needed later in the manufacture of more complicated work. In this way practically all bench work in a trade school can be done without loss of material. Small articles can often be made from the scraps of larger jobs and if they take the place of exercises, their selling price is clear profit.

The overhead charge of 20 per cent which is usually added to large jobs is not enough for small pieces. The amount of materials consumed in making small pieces is not large, and frequently most of the work is done on the machines, thus making the value of the labor very low also, so that the selling price of the article often figures out ridiculously low. On such jobs overhead charges of more than 20 per cent should be made; sometimes 100 per cent is not too much. The selling price need not be below the local commercial prices, because very often the materials used by the schools are better than those used by factories. Prices should not be above local commercial prices, however, and the fact that many articles made by machinery in a factory must be made by hand in a school, should be taken into account when fixing prices. Panels and intricate mouldings come under this head. As a rule, however, factories do not care to bother with small jobs and they usually have a fixed minimum charge so that a trade school can do a small amount of this kind of work quite as cheaply as a factory. This consideration, then, needs to be taken into account only on large orders, or on an order for a piece practically the same as the factory-made article. Special designs made according to the buyer's specifications are usually expensive, no matter where they are made, and full value for the hand labor should be charged.

Work accomplished during the regular shopwork periods for which students receive no pay should be charged just as if it were paid labor. This is a legitimate profit for the school. If the paid labor and materials consumed in an article cost ₱4.80 and the selling price is fixed at ₱5, many buyers seem to be of the opinion that the school loses no money. In other words, they believe that when the school turns out a good piece of work, the selling price should be just high enough so that no money will be lost in the operation. The trade school, however, is a business proposition and if the right kind of articles is made, regular prices should be charged when the materials, labor, and finish are at least the equal of factory-made goods.

Great care must be exercised in the purchase of lumber and supplies, for every peso's worth of unserviceable material will

mean a deduction of one peso from the profits of the school. Lumber may be checked, it may contain much sap, or it may be full of black knots and knot holes, all of which cause unusually large waste and corresponding loss when such lumber is paid for as first class stuff. It frequently happens that the supplies ordered are not in stock, and substitutions are made without permission. Such undesirable and inferior articles, if substituted and sent without permission, should be returned. Worthless lumber and inferior tools and supplies are a dead loss to the school and must be avoided if satisfactory profits are to be made.

Office furniture, such as can be afforded by the municipalities, is very profitable work, especially when they can be made in large quantities. A job of twenty or twenty-five pieces does not need much more supervision than a job of one piece and certainly causes no more work for the drawing room. On an order for one piece, where a working drawing must be made that requires several hours of the drawing teacher's time or several periods of a students' drawing class, and where there is no possible chance of using the drawing again, the value of the drawing should be considered in fixing the selling price of the article. In machining lumber for a large order of similar pieces, quite a bit of time and materials is saved as compared with doing the same kind of work for a large number of small orders.

The work in the school should be systematized and students should not be permitted to go about their work in a haphazard way. The students should be called together upon starting a big order. The drawings should be fully explained and the best way of doing the work should be mapped out. When each student understands what he is to do and how it is to be done he can go about it in a business-like way and save time which he would otherwise waste later in waiting for instructions. All the wood should be planed and sawed at one time. Much time is saved by using the machinery whenever and for whatever possible, though no student should be permitted to stand around and wait a longer time for his turn to use the machinery than it would take him to do the work by hand. It is better to run the engine one hour every day than to run it three hours twice a week. This will prevent machine work from being held up for the regular running day. It pays to start the engine for even a half-hour's run, since more sawing and planing can be done by one person in a half-hour than the

whole student body can do by hand in an entire afternoon, and the only extra expense entailed is about two centavos for oil to heat up the engine and get it started.

A sandpaper machine can be made easily by putting a spare pulley on a countershaft and gluing sandpaper on it, or if there is an extra mandrel it can be set up and a large drum built on it. Roll sandpaper can be bought for a large wheel and fastened on with a cleat so that the paper can be changed readily without waiting for the glue to dry. A table over the wheel will aid in keeping straight the pieces to be sandpapered. A machine of this kind saves considerable sandpaper and many hours of time.

Carved work should be discouraged. Occasionally carved feet or legs may be put on tables, chairs, etc., but large orders should not be taken for carved articles. Carving takes too much time and does not furnish a good livelihood to a pupil after he leaves school. Large orders for very fancy furniture should be avoided. Desirable orders call for straight lines and easy curves. Furniture is, to a very large extent, the main output of trade schools, but it must be remembered that the students should not have the greater part of their time taken up in making fancy curves and carved work, because the majority of them are not going to make furniture when they leave school, but will probably get work as carpenters, housebuilders, bridge builders, or other positions of this nature.

GRADED ON CHORES.

The report blanks provided in Adair County, Missouri, have spaces on one side for the grading in school subjects by teachers. On the other side they have spaces devoted to "industrial work," where the parents grade their girls on sweeping, dusting, baking, sewing, washing dishes, and ironing. Boys are marked by their fathers on feeding stock, milking, currying horses, providing fuel, and feeding poultry. Blank spaces are left for other sorts of home work. In a note addressed to teachers and parents, Superintendent Sipple says: "Pupils get credit for the work they do at home. Home grades should be considered by the teacher in making the final grade and to determine promotion."

FELLING, SAWING AND SEASONING TIMBER.

By E. E. SCHNEIDER, Wood Expert, Bureau of Forestry.

IN ORDER to avoid or to surmount the difficulties encountered in converting the trunk of a tree into timber that shall be serviceable and of pleasing appearance it is well to understand the causes of the phenomena that take place during the processes of cutting and drying the raw material; and to understand these causes it is necessary to acquaint one's self with the structure and qualities of that very complex substance, wood. Before entering, therefore, into the methods of conversion, the most essential properties of our material will be discussed.

PROPERTIES OF WOOD.

Some mention has been made in a previous article¹ of the most conspicuous elements in the minute structure of wood as seen in the cross section. Little attention will be given to these details in the present discussion, except to mention certain elements whose relative size, abundance, etc., may affect the behavior of wood in seasoning or under the tools used for working it. Rather, it is desired to consider here the occurrence and behavior of these elements in great masses.

Wood is composed primarily of numerous longitudinal fibers which lie, broadly speaking, parallel to the axis of the tree. Beside these, there is a set of radial fibers which lie horizontally, at right angles to the axis. The former constitute the bulk of the wood and their thickness, arrangement, color, etc., determine the appearance of the "grain" of the wood. The latter, which form very thin, flat bundles, the pithrays, are not generally conspicuous in any but a radial, or nearly radial, section, where they form the broad, irregular stripes known as "silver grain" and "flake grain," as for instance in Oak, Catmon, and Agoho. In species where the pithrays are both large and numerous, they may form as much as one-fourth of the total bulk of the wood, but in most species they amount to much less than this. It is unnecessary to discuss here the several different kinds of fibers. It is enough to state that they are hollow and that in living wood they are largely filled with water and in perfectly dry wood contain air in their cavities.

¹ Methods of Identification of Philippine Woods, THE PHILIPPINE CRAFTSMAN, December, 1912.

The varying weights and densities of different woods when dry do not depend on any quality of the wood substance itself, but on the thickness of the walls of the fibers. The substance of the wood weighs about 1.6 times as much as water. Light woods float because of the air contained in the fibers. If soaked until the water enters into the cavities of the cells and drives out all or most of the air, the lightest wood will sink. If the escape of the air and entrance of the water are made easier by breaking the fibers, the wood will sink sooner. Sawdust will sink very soon, because most of the fibers in it are crushed or torn. A very fine shaving taken across the grain with a sharp plane will sink almost as soon as it gets wet, because almost all of the cell cavities in it are cut across.

Trees grow in thickness only by adding successive layers of wood to the outside, just under the bark. The wood of very young trees is generally light colored and soft. In some species the color of the wood changes little or scarcely at all as the tree grows older, as for instance in Lanete. Of such trees we say that they have no distinct sapwood and heartwood. In the great majority of trees, however, there begins at a certain age the formation of heartwood, which is caused by the infiltration of various substances into the cell walls and, in some kinds, also into the pores and cell cavities. This process begins at the center and, once begun, keeps about even pace with the growth of the tree, so that the surrounding layer of sapwood forms a ring of practically the same thickness at all future stages of growth. The heartwood is darker, harder, heavier, and stronger than the sapwood; in trees possessing a peculiar odor, or colored deposits in the pores, or other peculiarities, all such qualities are more pronounced in the heartwood. Also, the heartwood is generally more durable than the sapwood. In trees having no distinction of color between heartwood and sapwood, there is generally very little difference between these in strength and durability; in those where the color of the heartwood merges gradually into that of the sapwood, the difference in quality is not great; while in those where the dark heartwood is sharply distinguished from the light sapwood, the latter is generally much inferior to the former, especially as regards durability.

It must be remembered that all the foregoing statements about heartwood and sapwood are only broad general rules. There is hardly one of them without some exceptions. One notable exception is so common that it should be mentioned. It often occurs that the inner portion of the heartwood of large trees

is distinctly lighter and softer than the outer, newer part. This is due to the fact that, when young, many trees grow very rapidly, forming a light, porous wood, and later grow more slowly, when they form denser wood. This is common, for instance, in woods of such widely different characters as Red Lauan and Molave. In such trees, when fungi or insects gain access to the interior through wounds in the bark, rotten knots, fire scars at the base of the tree, etc., they naturally penetrate the soft inner wood more rapidly than the hard shell surrounding it. This is the commonest cause of worm eaten and of "brash," "punky," or "doty" heart.

The successive layers of growth have a considerable influence both on the appearance and behavior of wood. When the fibers in the successive layers are all parallel, the wood is "straight-grained" and is generally easy to split in any direction and easy to plane along any straight section. But often the fibers of the layers, instead of being parallel, twist spirally around the



Fig. 1.



Fig. 2.

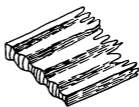

Fig. 3.

trunk in opposite directions. Such wood may split quite easily between the layers, that is tangentially, but radially it will split in the manner shown in figure 1. This fact is of little importance in the sawmill, as lumber is sawn, not split, but two other difficulties are caused by this peculiar structure. Boards sawn radially from very cross-grained woods often warp and shrink in a wavy shape in the manner shown in figure 2,¹ which reduces their effective thickness and causes additional work in finishing. The other difficulty is that such boards are very hard to plane; as the grain runs alternately "up" and "down," planing the wood in either direction leaves a series of alternate rough and smooth stripes. Once well surfaced, however, this feature gives the much admired "ribbon grain."

The growth rings also vary in color, hardness and density. Generally, where any differences exist, the inner part of each ring is softer, lighter colored, and more porous than the outer

¹ It must be understood, of course, that this and fig. 3 are exaggerated both as to the depth and the regularity of the corrugations.

part. The difference in hardness and density will cause a radially sawn board to shrink as shown in figure 3, with the same resulting loss of material and labor as in the previous case. Of course, in boards sawn otherwise than radially, these two peculiarities of structure will cause all sorts of irregular shrinking and warping.

So far, the fact of shrinking has been assumed without considering why it takes place or how it acts on a piece of timber as a whole. Shrinkage of timber is due almost wholly to the evaporation of the water in the wood. Water forms over nine-tenths of the contents of the living cells in the tree; it saturates the walls of the cells, both the living cells in the sapwood and the dead cells in the heartwood; and finally, it partly fills these last. There is more water in the sapwood than in the heartwood. Soft woods contain more water than hard.

Wood begins to lose water as soon as the tree is felled, or killed by girdling. At first, the loss is very rapid, but after a few days or weeks, it goes on very slowly, so that a large log will not become dry inside for years. Thin boards dry much more rapidly than heavy pieces. Ultimately, any piece of timber will reach a state of equilibrium, when it will lose or absorb slight quantities of moisture according to the condition of the atmosphere. Such lumber is called "air dry." If this is heated in a kiln to a little above the boiling point of water, it again loses moisture until, after some days, no further loss of weight is observed. Then it is called "kiln dry."³ Suppose now that a piece of green wood weighing 200 pounds has lost 100 pounds in drying; then we say that it contained 100 per cent of water, that is, the weight of moisture is expressed as a percentage of the weight of the dry wood. As yet no accurate data are available on the moisture content of Philippine woods. It is probable, however, that there is no very great difference in this respect between the woods of the tropics and of the temperate zone. The following extract⁴ shows the extreme variations in different woods and in heartwood and sapwood of the same kind:

Pounds of water lost in drying 100 pounds of green wood in the kiln.

	Sapwood.	Heartwood.*
Pines, cedars, etc.	45-65	16-25
Poplar, cottonwood, basswood (soft, light woods)	60-65	40-60
Oak, beech, etc. (hard, heavy woods)	40-50	30-40

* Most kiln drying is done at temperatures rather lower than the boiling point.

⁴ From "Timber" by Filibert Roth, Bull. 10, U. S. Dept. of Agr., Div. of Forestry, 1895.

The very low moisture content of the heartwood of pine is due to its being almost completely filled with resin; except the two pines (Benguet Pine and Tapulao) there are no Philippine woods that can be well compared with the American pines. The woods in the second line may be compared with Calantas, White Lauan, White Nato, etc., and those in the last line with Tindalo, Molave, Acle, and others. The highest figure in the table, 65 lbs., is equivalent to 185.7 per cent of the weight of the resulting kiln-dry wood; the lowest figure (excluding the special case of heartwood of pine) to 42.8 per cent. It is possible that some of the densest Philippine woods, such as Mancono or Camuning, may contain even less than the latter figure, or such as Taluto and Dapdap, more than the former.

Careful tests of thoroughly air-dried timber, both in America and here, show that it contains from 7 to 15 per cent or more of moisture, the average being between 11 and 12 per cent. Kiln-dried timber reabsorbs moisture almost to the same amount.

As wood dries, it shrinks. If it were a homogeneous substance, this would affect only its size and not its form. A pressed brick, made of well-ground and tempered clay, shrinks evenly without any distortion. But wood is far from being homogeneous. So it shrinks unevenly, and to this are due, excepting decay and destruction by insects, all the evils wood is subject to in seasoning. For warping, splitting, twisting, and checking are all results of unequal shrinkage.

It is well known that lengthwise wood shrinks hardly at all. A fact that is not so commonly known is that in a tangential direction it shrinks from two to three times as much as radially. This is due principally to the fact that the pithrays resist being compressed longitudinally and this fact is the cause of most of the splitting and warping both of heavy pieces and thin planks.

The amount of shrinkage varies greatly in different woods. Experiments made in America show that green boards, air dried, will shrink in width about as follows: light, soft pines, about 3 per cent; hard pines and wood of old oaks, 4 per cent; various other woods, some hard and some soft, 5 to 6 per cent; hickory (a very tough and hard wood) and wood of young oaks, up to 10 per cent.*

* A fresh-sawn Guijo plank donated to the museum of the Philippine Bureau of Forestry in February, 1911, was exactly 48 inches wide; exposed to the air under an open shed, it shrunk to a little over 45 inches by August, 1911; during the extraordinary dry weather of the spring of 1912, it went down to exactly 45 inches, a total shrinkage in width of $6\frac{1}{2}$ per cent; since then it has reabsorbed some moisture and now (February, 1913) measures 45 $\frac{1}{2}$ inches.

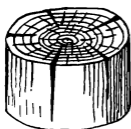

Fig. 4.

It is commonly believed that all soft woods shrink more than do hard ones. This impression is probably due to the fact that they shrink more rapidly, so that the shrinkage is more noticeable, and also to their being often used very green for cheap and temporary work, while the harder woods are generally at least partly seasoned and so do not open up so much after finishing.

Figure 4 shows the effect on a round log of the excess of tangential over radial shrinkage. From the same cause, the boards on either side of the heart of a log tend to warp outward as shown in figure 5. In figure 6 are shown the various ways in which squares cut from different parts of the log will act. (The hollowing of the faces is partly due to another cause, which will be explained further on.) The square (a) will check on all faces; (b), which has the growth rings and pithrays running diagonally across it, will be distorted into a parallelogram; (c), which has them at right angles to its faces, will not be distorted, but will become narrower one way than the other; and (d), which is part sapwood and part heartwood, will shrink more in the outer than in the inner half. It is the exception, of course, that any one of these causes acts alone on a given piece; two or more of them acting together may produce all sorts of distortions and checks.

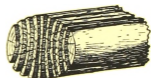

Fig. 5.

When a timber is exposed to the atmosphere or to artificial heat, the water evaporates first from the surface. A thin outer layer may be almost perfectly dry, while the inside is still wet. Let us suppose a heavy timber to be dried approximately as far as the dotted line in figure 7. This outer shell cannot, of course, shrink except within its own thickness, for,

to contract as a whole, it would have to compress the whole wet core. But being partly dry, it hardens or "sets" in the form and size determined by its own shrinkage and by the resistance of the core. This is called

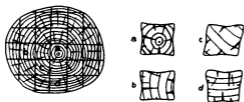

Fig 6

"casehardening." Generally, the shell cracks more or less deeply from the surface inward. Straight-grained woods that split easily check deep and wide in a few places; cross-grained woods become covered with a network of fine "superficial season checks." When the interior of the



Fig. 7.

piece begins to dry, it shrinks in its turn and tries to pull the shell with it. If the wood is one of a loose structure, that does not become very hard and stiff in drying, the shell follows the core and the superficial checks close, sometimes so completely as to show only as fine lines. Since the four corners of the shell are stiffer than the flat sides, they shrink less and the four faces become more or less hollow, as shown in figure 6. If, however, the wood is one that "sets" very hard and stiff, the shell refuses to follow the core, and the latter, trying to shrink and restrained by the stiff shell, has to split internally, as shown in figure 7. This is called "honeycombing." Sometimes all three of these things, more or less deep surface checking, hollowing of the faces, and honeycombing, take place in a single piece of timber. Honeycombing occurs most easily in woods having very broad pithrays, like the oaks, and in large dimension timbers, but one very severe case of it is reported in some 2-inch planks of Calantas at the Philippine School of Arts and Trades.

The more rapidly timber is dried, the more pronounced is the casehardening. It is worst in steam or fire heated dry-air kilns. In kilns where steam is admitted, the wood hardly case-hardens at all. Most woods dried in the open air, but not exposed directly to the sun, will not caseharden enough to do any harm; but if a large timber is dried, even slowly, and then sawn into boards, the outer boards will warp as shown in figure 8, on account of the fresh, soft surface shrinking more than the old, hard one.

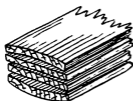

Fig. 8:

117045—4

A certain but very small amount of casehardening takes place under almost any circumstances. It is probably due to this that even seasoned boards, if replaned, again shrink a little. The hardened outer surface being removed, the fresh surface perhaps loses a very small additional percentage of moisture,

and being released from the restraint of a part of the "shell," shrinks a little more.⁶

So far there has been considered in connection with the structural peculiarities of wood only the mechanical effects of moisture, or rather the removal of moisture from the wood. Before discussing the methods of conversion, we should consider another very different, but also most important, effect of moisture on wood. Wood cannot decay except in the presence of moisture—that is, wood does not rot of itself. All forms of decay in wood are caused by bacteria or by fungi. Seasoning wood, provided it is done early and rapidly enough, absolutely prevents decay and even incipient decay is stopped by subsequent drying. Fungi are plants whose soil is vegetable or animal matter, but they cannot grow without oxygen and water, though many of them do not require light. Completely and permanently submerged in water or buried so deep as to prevent the access of air, wood does not rot because the fungi are deprived of oxygen; exposed to the air, but protected from water, it does not rot because the fungi can obtain no moisture.

Different kinds of decay are popularly known as "bluing," "wet rot" and "dry rot." Bluing, which is common in the sapwood of pines, in Cupang and other white woods of the *Narra* family, in the white woods of the *Lanete* family, in *White Nato*, etc., is caused by certain bacteria. These apparently attack only the contents of the cells, but not the cell walls, so bluing affects the appearance of the wood, but has very little, if any, effect on its strength. Wet rot is that which takes place where the presence of moisture is evident to the eye. The fungi that grow in the wood attack and in time completely destroy the cell walls. Dry rot is not essentially different from wet rot; many fungi can live and grow with only the small amount of moisture present in apparently dry wood.

Besides increasing the durability of wood by preventing decay, seasoning also makes many woods much less liable to the attacks of wood-destroying insects.

Rapid seasoning is desirable for woods much subject to bluing, rot, or insect attacks. In all other respects, except as a matter of economy of time, it is undesirable, for the more rapid the drying, the worse are all the mechanical defects caused by shrinkage, casehardening, etc.

⁶ The fact is well known to woodworkers. A lumberman in Manila reports a case of a wide *Molave* plank 21 years old which, on being replaned on both sides, shrunk a few millimeters in width.

All the advantages of seasoning wood before using it may now be enumerated:

(1) It prevents decay, if the wood is not subsequently subjected to moisture; and even under the most severe conditions, a well-seasoned piece will decay more slowly than one put into place green.

(2) It lessens liability to insect attacks.

(3) It decreases the weight, which is almost always an advantage, as great weight is desirable in wood only for certain special uses.

(4) It makes wood harder, stronger, and stiffer.

(5) It lessens the liability to shrinking, splitting, checking, and warping.

(6) It increases the capability for receiving and retaining a fine and permanent finish.

FELLING.

Opinions vary widely as to the influence of the time of year on the process of manufacture. Most producers and consumers state that timber seasons better at certain periods of the year than at others, but as some connect this with the rainy or dry seasons, others with the hotter or cooler seasons, and still others favor certain months of the year with no apparent regard to humidity and temperature, it is impossible to draw any conclusions from such conflicting testimony. One of the most experienced lumbermen in Manila states that a Spanish forest officer first called his attention to the fact that the logs felled from November to January sawed and seasoned best and that this was confirmed by experience with logs from Cagayan, Mindoro, southern Tayabas, and Mindoro. This would seem to indicate, as including logs from such widely separated regions, that our trees probably contain the least moisture during the coolest season of the year, irrespective of the rainy season. Nevertheless, it would seem extremely probable that in regions having a long and strongly pronounced dry season, this must have a stronger influence on the moisture content of a tree than would the temperature.

In one case certainly, namely, if logs must remain some time in the forest, it is better to fell them during the dry season, as the rapid drying out of bark and sapwood will make them less liable to decay and insect attacks.

Practically all lumbermen are agreed that there is no advantage in seasoning in the log. The slight amount of drying

that takes place in no way compensates for the severe surface checking, splitting at ends, and damage done by insects and fungi. This refers, of course, to logs lying in the forest or piled in the mill yard. With logs rafted to their destination and left in the water until ready to be sawn, the case is different. Logs submerged in water not only suffer no loss from insects, but little or none from rot, while practically all manufacturers are agreed that they saw more easily and that the lumber sawn from them seasons more evenly and, it is said, even more rapidly.

Summing up, then, the following seem to be the best rules for felling:

(1) Trees should be felled either during the coolest or the driest season of the year; in most cases, the latter rather than the former.

(2) Logs should be left in the forest as short a time as possible; if it is necessary to leave them for any length of time, the bark should be peeled off; in case of very valuable individual logs, they should be raised a little off the ground; the ends should be covered with tar, very thick paint, or a paste of carabao dung and stiff clay, to prevent too rapid drying and consequent splitting of the ends. If the logs are to be rafted, they should be taken from the stump to the water as soon as possible and, on arrival at their destination, left in the water until ready to be sawn. To this last procedure, there are two important exceptions: one in the case of timbers known to stain badly in water and the other in the case of teredo-infested waters; in both of which cases, the logs should, of course, remain in the water as short a time as possible.

SAWING.

It is easily seen from figures 5 and 6 that the boards least liable to warp are those sawn radially from the log; also, it is known from mechanical tests that such pieces are generally stronger and stiffer than those sawn tangentially; moreover, they season more rapidly, for water evaporates twice as fast from a radial as from a tangential section; and finally such boards have, in many woods, a more beautiful grain than the others, such as the "silver grain" in Oak and the "ribbon grain" in cross-grained woods. Wood sawn radially is called "rift-sawn" and "quarter-sawn;" that sawn tangentially, "flat," "slash," or "bastard." In America and Europe many methods have been tried to produce the maximum amount of rift lumber from a given log.

Three of these are shown in figure 9; from the first of these, in which the log is first quartered and these quarters sawn up diagonally, came the term "quarter-sawn." All methods of quarter-sawing involve more handling of the timber and also more waste in "edging" the product to uniform widths, but the improvement in stability, strength and appearance pays for this additional expense. In the Philippines, quarter-sawing is at present unknown, and if introduced, it will probably be only for certain woods and for special purposes. In such woods as Narra and Tindalo, which warp very little, it will probably never be used to any great extent. Moreover, the element of the appearance of the much admired "silver grain" does not enter into the question to the same extent here as in America, as the majority of our hard woods have only rather inconspicuous pithrays. In woods of very homogeneous structure there is little difference in appearance between rift and slash sawn boards. Such are:

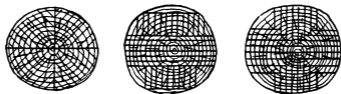

Fig. 9.

Amuguis, Aranga, Bancal, Bansalaguin, Calamansanay, Dungan, Ebony, Lanete, Malacadios, Baticulin, Mangachapuy, Pagatpat, etc. Except Amuguis and Bansalaguin, which are liable to warp rather badly, the above named are all woods that behave pretty well in this respect. Ring-porous woods, and those that have conspicuous regular or irregular rings of color, generally show a more wavy and florid figure when cut tangentially than radially. Such are: Banuyo, Batitinan, Benguet Pine, Calantas, Dao, Narra, Palo Maria, Supa, Teak, Tindalo, and others. Among these, Batitinan, Dao, Palo Maria, Supa, and probably Pine, are liable to warp badly if not very carefully seasoned. It will be seen that here taste sometimes conflicts with practical considerations; many people prefer the florid figure of slash-sawn boards to the straight "ribbon grain" of rift-sawn stuff. There is no doubt, though, that for such purposes as flooring, siding, ceiling, or broad flat surfaces in furniture, the practical side should be considered first and rift-sawn boards selected for these uses.

As there is no selected quarter-sawn stuff on the market in the Philippines, the consumer must do his own selecting. Provided the ends of the boards are neither dirty nor very rough, this is not a difficult matter except in woods of extremely homogeneous structure. All boards that have the rings running approximately square across from face to face are quarter-sawn. In the American lumber trade, specifications for quarter-sawn pine flooring generally admit all pieces in which the rings form any angle from 90 to 45° with the face, those pieces in which the divergence of the rings from the perpendicular is more than 45° being rejected. These conditions are shown in figure 10; (a) and (b) are rift, (c) slash or flat grain.

In ordering lumber from merchants (or, in the case of trade schools, generally from the Bureau of Supply) the purchaser has little or no choice as to the method of sawing. He can only stipulate that the lumber be of certain kinds and sizes and be free from certain defects. In obtaining lumber from local sources

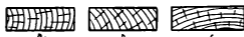

Fig. 10.

of supply, however, as is often done by provincial trade schools, the purchaser can frequently exercise considerable control over the methods of conversion.⁷ Large logs can generally be sawn both economically and with an improvement of the product by using some adaptation of the methods shown in figure 9, cutting them first into large cants or flitches⁸ to be marked and sawn into boards or small dimension timber. Such pieces, however, should be sawn as soon as possible into approximately the dimensions in which the wood is to be used. Not only will the smaller pieces season more rapidly and thoroughly, but the

⁷ In this connection attention should be called to the waste involved in the almost universal practice of squaring logs in the forest. The waste in squaring a cylinder is about four-elevenths of the volume (36.34 per cent). There is afterwards no choice as to the direction in which the log is to be sawn. If, as often happens, one or more heart cracks run diagonally through the log, every board they reach will be split, whereas in the round log the sawing can often be done parallel to the biggest crack. Quarter-sawing is out of the question, as the resulting waste would be two or three times as great as in the original round log.

⁸ Terms used in lumbering for large pieces intended for resawing.

danger of casehardening and subsequent warping (as shown in figure 8) is avoided.

SEASONING.

Since the invention and development of kiln-drying, it has sometimes been stated that it is impossible to season wood naturally as well as it can be done in the kiln. Given time enough, as has already been said above, wood will dry out so far that it no longer shrinks or swells except to the very slight extent caused by changes of the atmosphere. Kiln-drying reduces to a very slight extent the capacity of wood for absorbing moisture from the air, that is, a piece of kiln-dried timber will reabsorb less water than it contained when thoroughly air-dried, but the difference is very slight. One of the largest manufacturers of dry-kilns in the United States says in his prospectus that kiln-drying is only a rapid way of doing what nature does better though at the expense of more time. This statement, however, refers only to certain woods that are particularly difficult to season; with all woods that season easily and well, kiln-drying gives results as good, and sometimes better, than air-drying.

To dry sawn timber properly by natural means, two things only are essential: protection against sun and rain, and ventilation. Green lumber exposed to the sun warps, checks, and splits more than it does under cover, and alternate wetting and drying intensify all these defects, besides increasing the danger of decay. Lumber piled in solid piles, or in a closed storage place, dries out slowly or not all and, unless of an extremely durable species, rots before it dries.

The prime requisite then for storing fresh or only partly seasoned timber is a roof; of what kind is of little importance as long as it is large enough and tight enough to keep sun and rain from the lumber pile. Second, the lumber should not lie on the earth, or on the floor of the building. Stone, cement, or wooden cross sills should be provided to hold the pile 6 to 12 inches above the ground. Third (and this is by no means the least important item), no two pieces should be piled on top of each other; thin cross sticks (one-half to 1 inch) must be put between every two layers and, if the timber consists of dimension pieces more than two inches in thickness, narrow spaces should be left between the sides, so that the air can circulate about all four faces of every piece. The cross sills for boards one inch or less in thickness should not be less than

one meter apart. If the tops of the cross sills are broad, a stick should be laid on each one under the bottom board of the pile.

Heavier timber, such as 2-inch or 3-inch plank and large squares, may be laid on fewer cross sills, but no ordinary dimension timbers should have less than three points of support, except perhaps very short heavy pieces, such as, for example, a 10 by 10-inch by 8-foot piece.

The sticks should be of uniform thickness and no wider than necessary. They must be carefully laid in vertical rows above the cross sills, and the two end rows should be as close as possible to the ends of the lumber in the pile. If the pile is broad, so that a number of boards lie side by side, it is well to provide sticks long enough to reach clear across the pile, as in this way they help to keep the whole pile straight and level. To prevent the uppermost boards in a pile from warping, cross sticks should be put on them and weighted down with other lumber.

Too much care cannot be taken in the first piling of green lumber, especially anything thinner than 2-inch planks. Green boards lose the greater part of their moisture in the first few weeks and careless piling may cause them to take twists that no subsequent and more careful piling will ever remove.

If no roof, permanent or temporary, be available for storing lumber, a sloping cover of any material available should be put on the pile; a few sticks of wood or bamboo with some nipa shingles, a half dozen sheets of roofing iron, some slabs or old lumber will do better than nothing.

When it is necessary to enclose a shed to prevent loss of lumber by theft, a siding of strong bamboo slats or of narrow strips of wood is better than a solid wall. If a solid wall is put on, as of galvanized iron, for instance, ventilating openings should be provided at top and bottom.

Machine sawn lumber is often covered with a thick layer of the paste formed by the sawdust with the water used on the saw. If a supply of water is convenient to the yard or shed, it is advisable to wash this off. The wood will dry more rapidly for having the pores freed of the paste that chokes them; it will be much easier to select the pieces afterwards for special uses; and it is hardly necessary to tell any woodworker that planing a clean board does not require as much whetting of the plane bit as does planing a dirty one. There need be no fear of retarding the seasoning or encouraging decay (except in very perishable wood) by wetting it; the little water that soaks into

the surface of the boards will, in ordinary weather, evaporate in a day and, as to decay, there is much more likely to be a million fungus spores on the wood than a thousand in the water used for washing it.

Whether in the open or in a shed with an earthen or other floor, the ground around and under the piles should be kept clear of litter, such as sawdust, bark and chips, nor should weeds be allowed to grow up around the piles, as all of these furnish food and breeding places for insects and fungi. In any permanent yard, it is a good plan to cover the ground with sand, gravel, or cinders. It is perhaps unnecessary to say that if the yard is in a damp place, or one subject to flooding from heavy rains, the whole ground, or at least the cross sills, must be raised well above the danger line. If a shed is to be built purposely for storing in any but the very driest situation, it is best to raise it some feet above the ground on posts. In such a shed the most thorough ventilation can be secured by constructing the floor of narrow boards with half-inch spaces between them and providing windows, louvres, or a clear story immediately under or in the roof.

CARE OF SPECIAL PIECES.

In all the above directions, it has been assumed that a number of pieces of lumber of ordinary dimensions were to be treated; it often happens that trade school or other "crafts" shops have to take care of special pieces which have to be kept for some time before they are fit for working up. In such cases a little precaution and a small expenditure of labor will often prevent serious deterioration of a piece or a considerable amount of work in surfacing it.

It is a common practice to nail strips across the ends of planks to prevent them from splitting in transportation or while seasoning. While this is no doubt an excellent precaution for the first reason, there can be no greater mistake than to leave such a strip in position on a green board for any length of time. It should be remembered that green boards shrink from 3 to 10 per cent in width in drying, that is, a board three feet wide will shrink at least one inch and perhaps three and a half. Even a board of a wood not naturally disposed to split simply has to split when it shrinks if it has a stick nailed across the ends. The proper thing to do with such a piece is to put on

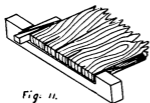

Fig. 11.

each end a clamp, as shown in figure 11, with a wedge or pair of wedges at the edge of the board. While the board is still very green, that is, for the first few weeks, the wedges should be inspected every day or two.

Later, a tap of the hammer once a week or so will keep them tight. It is, of course, impossible absolutely to prevent a board from splitting at the ends, but to a very large extent the split ends can be prevented from spreading and the split from becoming longer. If the wood is one in which warping as well as splitting is to be feared, the clamps should be made double, with cleats nailed across them as shown in figure 12. With such clamps wedges can also be used, if needed, though they are not shown in the sketch.

Round table tops often warp badly after they are "roughed out" from the buttress roots of which they are generally made. By putting on them two or three clamps of the second kind not only can the piece be prevented from warping, but a warped piece can even be partially straightened if it is not already too dry. For this purpose the clamps must be pretty heavy, say, 2 by 4 inches at least for a 5-foot table, and of stiff wood, such as Guijo, Apitong, Yacal, or Ipil. The 10-foot Dao table in the Forestry Museum was badly warped when it was received. By putting on three clamps of 6 by 8 inch timber, wetting the table thoroughly morning and evening and driving hard wedges under the clamps, in the course of a few weeks about 3 inches of warp were taken out of it.

Single-piece table tops and similar large pieces are generally more or less casehardened when received at the shop. To make them season at once more rapidly and more evenly, it is advisable to surface them roughly with the adze or even the jack-plane before putting on the clamps. If a piece is much thicker than necessary, it is well to do the dressing down in several stages at considerable intervals of time. In this way the casehardening becomes less severe after each successive surfacing and the danger of checking deeply is correspondingly lessened.

TIME REQUIRED FOR SEASONING.

The time necessary for thoroughly air-drying woods varies very considerably in different species. As a general

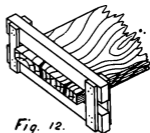

Fig. 12.

rule, soft, light, porous woods season very much more rapidly than hard, heavy, and dense ones. Rift-sawn boards season more rapidly than slash-sawn. Thin pieces season more rapidly than thicker ones; a 1-inch board dries out more than four times as fast as a 4-inch plank and more than twenty times as fast as a 10-inch timber.

A very large part of the moisture in wood evaporates during the first few weeks. Figures and diagrams of tests made by the United States Bureau of Forestry in 1902 show that green pine railroad ties piled in open piles out of doors lost moisture with great rapidity the first three to six weeks, then came a period of a few weeks when the rate of drying diminished rapidly, after which it became again steady but extremely slow. A typical case is the following: First three weeks, loss of weight of green wood over 30 per cent; end of next two weeks about 36 per cent; end of following six weeks, nearly 40 per cent. These tests were made during the hottest and driest months, June to September. Now the significant fact here is not the rapidity of evaporation in the beginning, but its extreme slowness during the last six weeks. During the following weeks and months it would certainly become still slower. Probably from one-half to two-thirds of the original weight of these ties (see table on p. 674) was water, so that, having lost two-fifths only (40 per cent) of their weight in eleven weeks and the rate of loss being now less than 4 per cent in six weeks, it is easy to see that it would take many months to reduce them even to an approximately dry condition.⁹ Although there are no exact data on the seasoning of Philippine woods, it is reasonable to believe that it will take place very much in the same way, and this is confirmed by the experience of woodworkers. For ordinary work, where only a fair degree of freedom from shrinking and warping is required, 1-inch boards of such woods as soft Narra, Calantas, Tanguile, and the Lauans can be used when a few months old, but for good flooring and inside finish and for fine furniture and cabinet work, they should be air-dried for not less than a year. Harder and denser woods such as Molave, Tindalo, Acle, Palo Maria, and, above all, Ebony and Camagon, require a still longer period. One-piece table tops, which are generally upward of 1½ inches thick, should never be made up unless known to be at

⁹ The shrinkage of the Guijo plank mentioned above was over one inch during the first month or so; after that it shrunk so slowly that sometimes scarcely any difference was noticeable from one week to another; but it continued shrinking for considerably over a year until the total shrinkage amounted to 3 inches.

least a year old, and then only after repeatedly dressing down as described above. And after all this, it is still advisable to make the screw holes in the battens a little bigger than the screws that are to go into them, so that the screws can give a little in case the top still persists in shrinking an eighth of an inch after the table is finished.

To those who may think these precautions excessive it should be remarked that, unless it is just out of the dry-kiln, one can never be absolutely sure that a piece of wood is even "air-dry", that one of the greatest virtues of fine wood-work is its permanence and that the appreciation of good quality outlasts the memory of the cost.

The *Journal of Education* for August 22 has an article by William H. Adams on "The Failure of Fundamental Education in Industrial Communities," in which the author points out the fact that too many of the lower schools are organized and conducted on the presumption that all pupils will continue on through the high school and perhaps some higher institution, whereas the training should have been suited to the hard facts and limiting conditions governing their pupils' lives. "It is true," says the author, "that we put our theories into cold storage and begin an overhauling of our schools in line with facts as they exist."

The same publication in its number for August 29 has an article on "Vocational Education," written by Dr. Frank W. Gunsaulus in his customary solid and elegant style. He cites the wonderful success of the continuation schools of Europe and says that "the industries and crafts of any district in our American land cannot be more healthfully related to public authority, than by the knowledge upon the part of workingmen and their children that society believes there is a special place for every one in the life and progress of the race and that every school, from the great central institution down to the remotest night school, proposes to make of each of its citizens something valuable and unique in the social organism."

ANNUAL CONVENTION OF DIVISION SUPERINTENDENTS.

THE eleventh annual convention of the division superintendents of schools was opened in the auditorium of the Philippine Normal School, Manila, on the morning of January 27, 1913, and was in session each morning to February 1. These conventions have been a source of much inspiration each year. They have offered an excellent opportunity for the Directors and the General Office to get into closer touch with the problems of the field and to adopt such measures as may be of assistance to those who have these problems to meet. The annual convention is, as it were, a clearing house, to which every man comes with his story of work done, difficulties encountered, and lessons learned by association with parents and pupils; where every man has an opportunity to help or to be helped; where the spirit of coöperation which has been so characteristic of the work of the public schools of the Philippines finds its highest expression and its most striking manifestation. It is at the annual convention that the young superintendent has an opportunity to hear from those who have had long years of experience the manner in which problems, not unlike those with which he has been confronted, have been solved and the means whereby difficulties not unlike his have been surmounted or removed.

The annual convention is in a large measure an experience meeting, but it is more than this. It gives an opportunity for constructive criticism on policies that have been adopted or methods that have been in vogue. It gives an opportunity to the man, who is a leader, to offer his original suggestions and have them discussed in a friendly, helpful manner. Through the recommendations of its committees it brings all of the best of such suggestions together in terse form to be adopted or rejected. Probably no other single feature of educational work has done more to bring about and maintain harmony of purpose and method, or to elevate to a uniformly high standard in every line, the achievements of the Bureau of Education, than has the annual convention of division superintendents.

Prior to the adoption of the custom of conducting an annual sales exhibit at Manila, some of these conventions were held at Baguio in connection with the Teachers' Vacation Assembly. During the last three years the conventions have been held at

Manila and have assembled either just before or during the yearly industrial exhibition of the Bureau of Education. This has given superintendents a favorable occasion for a study of the work of their schools in comparison with that of every other school division, and has made possible the discussion of industrial plans and methods and policies in a manner more practical than could have been possible otherwise. Due to this fact in large measure and to the emphasis which has recently been placed upon industrial instruction in the public schools, the annual convention of division superintendents this year, as in previous years, has devoted much of its time to a discussion of the various features of industrial education.

While the main discussion of industrial instruction was in connection with the report of the committee to which this topic had been assigned, yet this subject is so closely related with every phase of school work that it found its place in the recommendations of practically every committee. Much that will be helpful was presented. In the main it was found that industrial education has made healthy progress during the present school year. Provinces, in which the work left much to be desired a year ago, are now producing articles of a high standard of workmanship in practically all schools. The general plans adopted some three years ago for the promotion of industrial instruction in the public schools and for standardization in workmanship, design, and materials have been found helpful and productive of uniformly good results, so that at this convention it seemed to be the consensus of opinion that industrial work was rapidly assuming a more businesslike character and that no doubt could reasonably be entertained of the ultimate success of the present program.

Of the resolutions adopted by the convention several are worthy of special note. Among these may be mentioned the prevailing desire to place industrial instruction in both primary and intermediate schools upon a sound business basis. "Industrial instruction should be self-supporting." Pupils are to be taught not only deftness and agility, they are also to learn the practices of the business world. Simple accounting for municipal industrial operations along the lines followed in trade schools and shops, involving the distribution and investment of earnings, is to be a part of the industrial instruction offered in the public schools. Time was not available for the full discussion of such a system of accounting, but it was recommended that a standing committee of division superintendents

be appointed to make definite recommendations to the next convention.

It has been demonstrated that Filipino industrial teachers, acting as traveling instructors, are a great help in perfecting the workmanship in both basketry and needlework, and the custom of assigning teachers as traveling instructors or division industrial supervisors was commended. Such teachers can be of the greatest assistance in bringing to a high standard of excellence the work of the lower grades of the primary schools. The work of an entire school division can be improved to a considerable degree in a few months by an energetic and competent industrial instructor who, with a small collection of finished articles of a superior grade and pertinent literature, travels from town to town, suggesting and helping wherever suggestions or help may be needed. The work of such a traveling instructor, supplemented by an annual division institute and an occasional vacation assembly, is perhaps one of the most effective means for promoting a high grade of industrial instruction.

The recommendation that may have the most far reaching influence is that which has to do with vocational high schools. The convention was practically unanimous in its belief that a two year vocational course in connection with every high school was advisable. The high school is not merely to serve as a preparatory school for those students who desire to enter the university. Its chief purpose must always be to prepare the students for the life work that awaits them. The percentage of high-school students enrolled in the first two years seems to indicate that the great majority of these find it impossible to spend more than two years in the high school. It is with these students in mind that the two-year vocational courses are suggested. In addition to extending the industrial work of the intermediate grades into the secondary course, it was suggested that a course for the training of teachers be outlined to cover the first two years of the high school. It was the belief of the convention that such a plan would tend to supply teachers of a high degree of efficiency not only in industrial lines but in academic subjects as well.

The further establishment of farm schools was highly commended. It is felt, however, that until the field of agricultural science in the Tropics has been more fully explored, the greatest of caution will have to be exercised in the administration of such schools. Gardening in the primary schools has been successfully undertaken and it is suggested that farm schools at

first confine work to the cultivation of such vegetables and fruits as can be successfully cultivated, and to a few experiments for the purpose of gradually extending this limited field of activity.

The need of more definite information as to the real commercial value of the handicrafts which the schools are introducing was discussed. The convention expressed its approval of the efforts already made along this line and suggested that they be continued. The Sales Agent addressed the convention on this topic and his remarks were very encouraging. There is no doubt that the Philippines is, in many ways, a country in which handicrafts and household industries will prove a great source of wealth. It is evident, however, that before a further effort is made to introduce any industry or craft, it must be ascertained whether the output will find a market and whether those engaging in the craft will be able to do so profitably to themselves as well as to the community in which they live. It was suggested that the field be thoroughly canvassed in order to obtain such information upon these two points as might be of use to those outlining courses in industrial instruction.

This eleventh convention has been a source of inspiration to the directing force as well as to the division superintendents. All are nearer to a mastery of the school situation in its many phases than they were prior to the convention, and that the convention will be fruitful in better and larger achievements in industrial as well as in academic lines seems to be assured.—W. F. M.

Idleness is emptiness; the tree in which the sap is stagnant, remains fruitless.—HOSEA BALLOU.

o o a.

Plain clothes soiled by labor adorn, while fine clothes unearned disfigure the wearer.—*Selected.*

o o o

The Department of Education of the Government of Guam is giving special attention to industrial instruction and the plan which is followed is that of apprenticing young men who are desirous of learning a trade for a period of four years in government work. They are given a small wage which is increased in accordance with their proficiency and aptitude. Each apprentice is under the direct supervision of competent foremen and is allowed to choose from the following trades: Blacksmithing, painting, plumbing, carpentry, and mechanics.

Very gratifying results are reported.

TWO METHODS OF STRIPPING ABACA.

By HAMMON H. BUCK, Division Superintendent of Schools, Batangas.

CAVITE abaca, known as "Indan abaca" from the principal commercial center of the district, is sold regularly in Manila for about 10 per cent more per picul than the abaca from Batangas and other provinces having soil and climate similar to that of Cavite.

The circumstance would seem to demand an explanation. There is no reason why there should be such a difference in the prices of a product grown under exactly the same natural conditions in neighboring provinces. Manila dealers affirm that the Cavite fiber is whiter and more lustrous than that from other provinces, and since this class of abaca is used almost entirely in the higher grades of textile articles, there is a strong demand for the best fiber.

Some owners of abaca plantations in Cavite claim that there are different varieties of abaca, one in particular being known as "abacang siniboyas" so called from the resemblance of the fiber in color and luster to the white onion. The writer has examined this claim of "different varieties" and has found that the variety known as "abacang siniboyas" seems to grow on high and rather unfertile soil, while the other variety, known as "kinalabaw" is dark, rather coarse in texture, and grows on low, fertile soil. The conclusion is, naturally, that the so-called different varieties, at least as far as Cavite is concerned, depend for their difference upon the nature of the soil in which they are grown. These local differences of soil occur in all provinces where abaca abounds and there doubtless occur, also, minor differences in the quality of the hemp produced in any one locality.

Some years ago it was noticed that buyers paid ₱2 or ₱3 per picul more for abaca produced in Mendes Nuñez and Indan than for the product from Alfonso, a town some 7 miles distant. On inquiry it developed that a different method of stripping was followed in Indan than that practised in Alfonso; this difference in the method of preparing the product apparently accounts for the difference in prices.

In Indan the method of stripping in vogue was known as the "bakkak;" while that in use in Alfonso at that time was known as the "baknis," which is the identical method followed in Ba-

tangas. As evidence that the difference in prices between the Alfonso and the Indan product was due to the difference in the method of stripping, it may be stated that since the Alfonso strippers have learned the "bakkak" method the price of Alfonso abaca has been the same as that of Indan.

In stripping by the "baknis" method, the strippers, after cutting the stalk and tearing it apart, separate the outer skin of the petiole known as the "lupis" from the pulp and pass it under the knife to clean the fiber.

Under the "bakkak" method the stalk after being cut is leaned against a tree. The operator then grasps the outer edges of the petiole with his fingers and tears it loose from the stalk, sinking his thumbs at the same time into the center of the petiole so as to split it through the middle from top to bottom. When the petiole is torn loose to within about 2 feet of the base it is bent so as to break off the thickest portion of the pulpy interior and leave it attached to the base of the trunk. The petiole, thus retaining a great part of the pulp, is cleaned in the same manner as is the "lupis" under the other method.

The explanation of the superiority of the latter method of stripping probably lies in the fact that since a greater quantity of pulp is gathered in front of and under the knife, the fiber is cleaned more by the pressure of this pulp than by direct contact with the knife. Consequently the outer skin of the fiber is not injured, hence the greater luster of the fiber cleaned by the "bakkak" method.

Another explanation is that under the "baknis" method, after the "lupis" has been separated from the petiole it is often left for some time before it is cleaned. As a result, the sap dries on the exposed fiber and discolors it. On the other hand, under the "bakkak" method, at no time during the process of stripping is the fiber exposed until it is finally cleaned.

Strippers say that it is somewhat heavier work to strip by the "bakkak" method than by the "baknis," but affirm on the other hand that sufficient time is saved in the method of preparing the petiole for stripping to compensate for more than the difference in the labor of passing the fiber under the knife. Moreover it is claimed that fiber stripped under the "bakkak" method is more uniform in length; that is, that the ends are not broken as much as by the usual method. This, if true, means greater returns for the owner of the field, in quantity as well as in quality.

VOCATIONAL GUIDANCE.

MARINE OFFICERS.

By FRANK P. HELM, Director of Navigation, and HENRY B. MCCOY, Insular Collector of Customs.

QUALIFICATIONS.

Best age for entering the occupation.—The best age for entering the occupation of marine officer is from 21 to 24 years. A young man entering the merchant marine at this age will be better able to adapt himself to the element of strict discipline, which is recognized as a fundamental part of the career of marine officers.

Educational attainments which prospective officers should have.—A prospective officer should have at least a common-school education, supplemented by a good knowledge of arithmetic, algebraic formulas, nautical astronomy, meteorology, and international rules and signals—familiarity with all of these subjects being a prerequisite for advancement in this profession.

Physical and personal requirements.—A prospective officer should possess a sound body, his hearing and eyesight should be excellent, and his ability to distinguish colors should be absolutely infallible. In addition, he should be polite, tactful, and courageous, and particular at all times in the matter of his personal appearance.

Opportunity for continuation of training for advancement.—After two years at school and eighteen months at sea, students may take an examination for a license, provided they have served one year at sea as a quartermaster. During the eighteen months' training at sea, they will be instructed in the handling of vessels in various positions, magnetism as it affects the compass, the handling and stowage of different cargoes, handling of men, and, above all, navigation.

At the present time there are 392 vessels operating in the coastwise trade of the Philippine Islands which require licensed officers, and the number of such vessels is increasing annually. The opportunity for continuation of training for advancement is excellent. The progress of a young officer depends only upon the amount of zeal with which he applies himself to his immediate duties and qualifies for promotion by observation and continued study.

THE OCCUPATION.

Nature of the occupation.—The nature of the occupation itself compares favorably with any other profession that a young man might elect to follow. The work is dignified and important and is steady throughout the year. It is very much more healthful than sedentary occupations that require a man to spend most of his time at a desk in an office. The officers are always in the open air, and no life is more healthful than the life at sea. There are no special dangers in the Philippine Islands, with the exception of occasional typhoons, which are usually mastered by officers who are both capable and cautious.

Owing to the fact that trade in the Philippine Islands is entirely coastwise, vessels are continually in and out of port and this feature of the work does away with any chance of strain or monotony.

The duties and responsibilities of the various positions on board the ship are well defined, and, except in cases of emergency, each officer has only his own prescribed work to perform. The work is varied and interesting, and a young man who enters this field will find an occupation in every respect worthy of his utmost endeavor.

Divisions of work involved.—The principal duties of a noncommissioned officer in the merchant marine are to check cargo on and off the vessel at the various ports of call, to superintend the proper handling and stowage of cargo, to make out the manifests of cargo carried on board the vessel, and to be on the bridge when going in and out of port, keeping a watch with the regular watch officer.

After obtaining a license, the student's first appointment will be that of third officer. This officer, in port, has charge of the quartermasters and wheelhouse; if on a passenger steamer, he will be at the gangway on arrival and departure of passengers; he will have charge of No. 1 hold, and it will be his duty to see that stevedores do not break or broach the cargo, and that it is properly dunnaged and stowed. On arriving at and leaving port, he will be on the bridge with the captain, handling the engine-room telegraph and keeping time of the same. At sea he will stand the captain's watch of four hours on the bridge and eight hours off. It will also be his duty to attend to such clerical work as the chief officer may require. After one year's duty as third officer, he will be eligible for license as a second officer.

The second officer, while in port, has charge of the afterend

of the vessel while working with cargo, and it is his duty to see that it is properly dunnaged and stowed. He also has charge of the afterend of the vessel while docking. At sea he has charge of the ship and assists the captain in navigating—on large vessels he is the navigating officer. After serving one year as second officer, he may apply for examination for the chief mate's license.

The chief mate has general charge of the ship and all officers and men, and, during the absence of the captain, he has command of the ship. After serving one year as chief mate, he may go up for examination for a master's license.

Opportunities for advancement.—The opportunities for advancement from one position to another are all that could be desired. Continued advancement in the service can be assured to those who are willing and quick to learn. Advancement is usually made by regular promotion, but depends to a great extent on the aptitude, ability, and willingness of the officer to study. By applying himself, an officer may obtain a higher license from year to year until he attains that of master. The opportunities for advancement in the Philippine Islands are excellent, since at the present time there is a scarcity of officers and an increasing demand for vessels. The shipping industry has a brilliant future, as the domestic commerce of the Philippines is increasing rapidly every year. Agriculture is being developed and sawmills are being established in different parts of the Islands. In a country like the Philippines, composed of thousands of small islands, transportation and trade by water will always be one of the leading industries. More ships are steadily needed to handle this growing trade.

Pay.—In addition to their salaries, all officers are furnished with subsistence and comfortable quarters on board their vessels. This enables them to curtail their living expenses to a minimum and to save sufficient money to permit them to live in comfort and ease upon retirement from the service.

The following table shows the usual salaries paid to officers per month in the Philippine coastwise trade, although the masters of certain vessels engaged in this trade receive salaries of ₱440 per month:

First-class vessels.

Captain	₱250
Chief officer	153
Second officer	105
Third officer	80

Second-class vessels.

Captain	₱210
Chief officer	123
Second officer	₱80 to 105

Third-class vessels.

Captain	₱190
Chief officer	113

Captains of first-class vessels are paid the sum of ₱25 per month in addition to their regular salaries. Captains of second and third-class vessels receive ₱15 per month over and above their regular pay. This extra compensation is in the nature of a bonus, and the practice of allowing the same is general as far as the ships in the Philippine Islands are concerned. Captains sometimes acquire a financial interest in the business of the vessels under their command, and in this way are able to add materially to their incomes.

COMMENTS.

A boy should not enter upon the vocation of a marine officer with the idea that his life will be one of ease and luxury. Sea life involves a considerable amount of discipline and, at times, very hard work, combined with many dangers, the majority of which can be avoided by an officer well versed in his vocation.—FRANK P. HELM, Director of Navigation.

I have seen young men rise within five years' time from mere noncommissioned officers at an allowance of ₱20 per month to the rank of captain, and captains generally leave their positions in good financial condition.—J. M. POIZAT, President of the Philippine Shipowners' Association.

[NOTE.—This is the fourth of a series of articles on Vocational Guidance. Other articles on this subject have been published in the October, November, and January numbers of THE PHILIPPINE CRAFTSMAN.]

The public, in giving support to manual training and the household arts, undoubtedly intends these subjects to promote closer relationship between the school and vocational life; some teachers of these subjects unquestionably do use them with precisely this intent; but efficient instruction presupposes something definite to teach and a consistent way of teaching it.—*Selected.*

EDITORIAL AND OFFICIAL.

SOME significant facts are worth noting in connection with the Carnival Industrial and Sales Exhibition just held. Nearly all the schools of the Islands were represented with specimens of work done by pupils. As a culmination of the general plan to display school exhibits, first in the various municipalities and provinces, and then at the Insular capital, the result met with wide approval. The advance in industrial standards in all branches of industrial work is to be attributed in no small extent to the opportunities afforded by these exhibits for the comparison of school products made in widely separated localities.

Industrial and
Sales Exhibition,
1913.

Particularly conspicuous was the uniformity of good work in the articles displayed, showing increased industrial skill on the part of pupils. The expansion and diffusion of new lines of work over a widely increased geographical area denoted the soundness of present plans for industrial instruction. The industrial materials used in former exhibits are now more widely applied than ever before, their application and use better understood, and the number of new materials entering into the fabrication of industrial articles is ever on the increase.

Articles in hand weaving and sewing were widely in evidence and constituted the main feature of the exhibition. A large part of this work has the unique quality of being distinctive of the country and of being made of Filipino materials. Probably the first abaca exhibit which has ever been held in the Philippine Islands was there displayed. The utilization of this material and the variety of artistic articles made from it have been among the surprising developments in school work. The large exhibit of prepared fiber specimens was equally noteworthy. As in past exhibits, the display of woodwork made in trade schools and intermediate shops denoted the degree to which Philippine woods are adapted for the making of the various high grades of furniture and the skill which Filipino pupils possess in bringing out these qualities through fine finish and good workmanship. The extent to which the agricultural work is being encouraged in Philippine public schools was evidenced by the collection of fruit and vegetables forwarded from all parts of the Islands.

The prosperity and the welfare of a country are intimately

connected with the economic development of its resources and the industrial training given to its citizens. This end will be secured in the Philippines, partially at least, through the training which pupils are receiving in the public schools and the introduction of industries into the homes of the people. The factory system has gained but a slight foothold in these Islands and in view of the probable future development of this country along agricultural lines, the extension and introduction of household industries will do much to bring about a higher state of social and economic well being.

In the initial number of the THE PHILIPPINE CRAFTSMAN, there appeared a rather extended editorial on the opening of schools. In this paper there was given a brief statement of the school industrial conditions prevailing at that time, with some suggestions as to the general trend which the work would follow during the year. Naturally, our hopes exceed our expectations, and our expectations are frequently beyond our actual accomplishments; so in this year's work, while in some particulars our accomplishments may have fallen short of the standard set, we feel that our purposes have been maintained and that the close of the schools marks satisfactory advancement in the industrial program.

Some Industrial Activities of the School Year.

One very gratifying condition which was emphasized at the annual industrial exhibit, held in Manila during the carnival, is the uniformity in the advance of industrial work throughout the Islands. Formerly certain divisions were marked by their progress in special branches; no longer is a single division in a class by itself. This is due largely to two things: the use of the exhibit, particularly the Carnival exhibit, and the systematic distribution of industrial information called for and received by the General Office.

The corn campaign has been followed systematically as one of the leading features of the school year. Its results cannot be estimated now, but it is certain from the attention which it has received from all classes of people that the possibilities of corn as a food are being brought out very forcibly, particularly in sections where an auxiliary food is needed. Announcement has already been made to the effect that the campaign will be continued for another year.

The interest which has been taken for some years past in school gardening has in no wise abated; sites for the construc-

tion of permanent schools are invariably chosen with the idea of providing ample space for garden purposes. For some time the home garden has been recognized as a part of regular school work. Without question the gardening feature of the school program is largely responsible for the improvement in the quality and quantity of fresh vegetables available in the markets of the Islands.

The School of Household Industries has been organized and some months ago graduated its first class of more than 125. These young women are now actively taking up the problem of establishing themselves in the lace and embroidery business in all parts of the Islands.

Some years ago, the first steps were taken to bring the demand for industrial materials, particularly for needlework, to the attention of Manila merchants. During the past year a very satisfactory beginning has been made and a number of merchants have cooperated with the Bureau in working out a system by which suitable materials can be promptly supplied at reasonable rates. More than ever before are the commercial interests, local and foreign, and the schools coming to a better understanding of the value of cooperation.

The expansion of the industrial information branch of the General Office and the work it has undertaken during the past year are notable. The numerous reports covering the investigations which are being conducted by the field personnel of the Bureau are here assembled, worked over, and put into suitable shape for immediate general use. In a broader way, through correspondence and exchange of publications, this office is keeping in close touch, not only with the trend of industrial education in countries in which similar conditions prevail, but also with the actual details of courses of study and industrial procedures in other more advanced countries.

The statement has been frequently made that the Directors look to the field for suggestions on all phases of this work. The reports of division superintendents' conventions and conferences of teachers and committees appointed for the consideration of such special problems as the revision of courses and the application of business methods to industrial instruction have had a very material influence upon the direction of this work.

The plan which was put into operation some years ago of designating a number of special industrial supervisors and inspectors has worked out so satisfactorily that, during the past year, it has been made a part of the system of industrial supervision. In nearly every case an industrial supervisor has

been designated for each of the 38 divisions, who is charged with the promotion of industrial instruction in his particular division. Some of these men, the product of the Philippine Schools, have developed to a point where they may be called specialists in certain branches. The Directors, in addition to personal inspections in the field, acquaint themselves more closely with conditions through a corps of traveling inspectors and supervisors attached to the General Office. The work is further standardized through a corps of some twenty Filipino specialists. These are sent out to give instruction in normal institutes and to give demonstrations in connection with traveling exhibits. When not on provincial detail, they are engaged in the creation of models from designs prepared in the General Office. The results secured by this corps have been highly satisfactory.

The trade schools and provincial school shops were the first vocational plants to be placed upon a satisfactory basis. During the past year this branch has been extended as rapidly as financial and other conditions permitted. In addition, the course of instruction for municipal shops has been more definitely determined.

Very recently the Philippine Legislature has made it possible to carry to completion the plans which have been under consideration for some time for the erection of a new plant for the Philippine School of Arts and Trades, which will be the most complete institution of its kind in the Philippine school system. In the construction of the new building of the Philippine Normal School, which was occupied at the beginning of the present school year, ample provision was made for the industrial branches which are a required part of its regular courses of study.

Two lines of investigation which have been carried on during the past year deserve special mention. These are in vocational guidance and in the working out of a series of designs that will be typical of the Philippines. In vocational guidance, we have followed generally the work done by leaders in the cities of Boston and New York. The aim is to acquaint the youth with the opportunities offered in the various trades and professions in which he may be interested. Much yet remains to be done in this respect. The study of typical Philippine designs has resulted in the gathering of much material and in the preparation of a number of models. This is an important and interesting feature of investigation in which a bare beginning has been made.

In the matter of publications having a direct bearing upon this field of activity, mention of a number of the most important pieces that have been produced during the school year, or are now in the hands of the printer, will include: Bulletins on the School of Household Industries; the Industrial Museum, Libraries and Exhibits of the Bureau of Education; a Civico-Educational Lecture on Corn; a textbook on Economic Conditions in the Philippines and one containing supplementary problems for trade schools and trade classes; a Bulletin on Philippine Industrial Fibers and one on the Nautical Department of the Philippine School of Arts and Trades; a reprint from *THE PHILIPPINE CRAFTSMAN* on the subject of Philippine Mats; and this first volume of *THE PHILIPPINE CRAFTSMAN*. In addition to these there have been quite a number of auxiliary pamphlets, circulars, folders, and announcements.

We have been able to mention here only a few of the salient industrial features of the school year. It is a big field for study; our work here is already engaging the attention of educational investigators from abroad. And the study which our office is giving to vocational instruction of other countries through the examination of reports and through correspondence, and more directly through the personal visits of representatives from our force, convinces us that our aims are along right lines.

The standards by which school progress is measured are many; in this hasty survey of the industrial progress of the school year, we must not lose sight of a higher purpose. We have had occasion to make frequent quotations from Dr. George Kerschensteiner, the distinguished Director of Education for the city of Munich, Germany. In all of his works, and as one of the significant features of his school system, Dr. Kerschensteiner emphasizes the point that the product of the school is the pupil trained to take his place as a useful citizen in the largest capacity. The secret of his success is that he eliminates the idea of drudgery and provides a natural course in which he teaches the boy with a task to perform that he is doing something worth while, and trains him to take pleasure in the proper performance of his school task and later of his life work; in whatever walk of life necessity and the choice of a trade place him, he is a valuable citizen. The program followed by Dr. Kerschensteiner finds its counterpart in the present educational system of the Philippine Islands. The industrial program of the Bureau of Education is one of the means by which it is hoped to realize the aim which has guided Dr. Kerschensteiner in his efforts to produce good citizens.

With this issue, the first volume of *THE PHILIPPINE CRAFTSMAN* comes to a close. In many ways the volume has been satisfactory to this office and has met with the approval of those who

The Closing
Number of
Volume One.

are in a position to criticize it and to judge of the manner in which it has come up to expectations. From the printer's standpoint, it is considered an excellent product. For those in the Philippines who are particularly interested in our school program, it has had much to offer and makes no apology.

True enough, many suggestions and recommendations have been received from various sources on its general make-up and contents; that which seems to be most timely is that another volume should be made more popular in tone; its contents should appeal more to the average teacher in the Philippines than to students of school conditions here, and its discussions should be less involved, less technical, less formal.

The *CRAFTSMAN* itself and the criticisms upon it which are offered from time to time receive due consideration from the directors, and are brought to the attention of superintendents and teachers for discussion and recommendation whenever bodies of such are gathered together. The directors and editors will continue to look to the field for suggestions as to the policies which they should adopt for the second volume, which will appear at the opening of the next school year.

From the original 1,500 copies which it was expected would supply the field of the *CRAFTSMAN*, the regular requisition has been increased to 2,500 copies per issue. Nearly 1,400 paid subscriptions have been received, including a considerable number from foreign parts and from concerns in the Philippines outside of the Bureau of Education which are interested in the industrial development of the country. In addition to these, some 500 copies are distributed officially for the permanent files of the offices to which they are sent. A considerable number are distributed as exchanges and among persons in the Philippines and elsewhere who should receive copies. The balance is held for file and for miscellaneous use. It was the original intention to have each number consist of 40 or 50 pages; in every case this estimate has been exceeded, some issues offering more than double that number. *THE CRAFTSMAN* has been more profusely illustrated than was originally intended and a number of color plates have been introduced. As indicative of the work in which this magazine has been interested, the editors would invite attention to the editorial appearing in this number on the industrial progress which has been made during the year.

In many of these activities the CRAFTSMAN has taken the initiative, and it has been interested in them all.

As stated in the dedication on its cover page, this is a school magazine devoted to the advancement of industrial instruction in the public schools in the Philippines. As such, it is confidently asserted, it is unique in the annals of school publications. Many school papers from abroad reach the editor's desk, each with a purpose which it must serve admirably; but we believe that THE PHILIPPINE CRAFTSMAN has a field of its own.

In closing this volume the editors make grateful acknowledgment to those who have had a part in the preparation of the material which has appeared in its pages, and who have followed its progress with kindly interest. The constructive criticisms and comments of those who have found it helpful have given us real satisfaction.

To the editors, to whom this magazine work is a new field, and whose time has been fully taken up with the manifold duties of one of the busiest years which the Bureau has known, the experience of the past has been of great value. Incidentally, it must be remembered that it is upon the division superintendents and industrial teachers themselves, principally, that the Bureau must depend for the success of such a publication. While their contributions to the first volume, perhaps because of inexperience and reluctance and of the too numerous other demands upon their time, have been rather meager, it is expected that for the second volume they will be more ready and prepared to assist. Their earnest coöperation is again urged.

With a word of suggestion to teachers and pupils to keep before them during the summer months the duties which the opening of schools in June will bring to us all, THE PHILIPPINE CRAFTSMAN wishes to its readers a pleasant vacation, not without a purpose and a serious side, and renewed vigor and enthusiasm for the next school year.

EDUCATING APPRENTICES IN GERMAN FOUNDRIES.

The education of apprentices in German foundries is described by Dr. Otto Brandt in a dissertation that is attracting considerable attention in this country.

"Various methods of instruction prevail. Frequently the apprentice is assigned to a skilled workman who instructs the boy and in return gets the larger pay resulting from the efforts of both. If the boy makes such good progress that the teacher-workman's earnings increase rapidly, the boy is paid part of

the proceeds. The pay is very small, however, from the American point of view. In large machine shops the foundry apprentices are formed into special classes for instruction in work. If there are not enough boys for a special class, they receive general instruction in the industrial continuation school.

"With some concerns all the apprentices are instructed together the first year, and specialize during the following three years. There is no uniformity with regard to subjects and time allotted them; the schools range all the way from one class with four hours a week of instruction to a complete three-class system with a preparatory department and 12 hours of teaching. Some of the schools give merely technical subjects, while others offer the customary continuation school branches.

"Industrial training of this sort is practically compulsory, it must be remembered. The employer is compelled to send all employees under 18 years of age to a continuation school for a prescribed number of hours per week. He is at liberty to maintain a school of his own, but it must conform to government standards.

"A typical school program includes: German, 2 hours a week, with letter-writing, preparing business forms, bills, receipts, etc., material, 2 hours, comprising a study of ore processes, blast furnace, Bessemer, open-hearth furnace, etc., and woods, their kinds, properties, and diseases; arithmetic, 2 hours a week, particularly business arithmetic—cost of materials and freight charges, etc.; drawing, 6 hours a week. During the latter part of the course business law, civics, and industrial history are introduced. Some of the schools have sessions from 7 to 9 a. m.; others 5 to 7 p. m., or at any convenient time; and a few hold sessions for an hour and a half or two hours on Sunday, though Sunday school work is no longer as frequent as it used to be, either in municipal industrial schools or shop schools.

"American foundrymen are interested in Dr. Brandt's description of German foundry-school conditions because of the light it may throw on the similar problem in this country; and they are especially impressed with his summary of the purpose of the continuation school, as quoted from the Prussian Minister of Commerce and Industry: 'The compulsory industrial continuation school should aim at the vocational education of the young people between 14 and 18 years of age, to promote that education, and to train them to become valuable citizens and respected men.'"

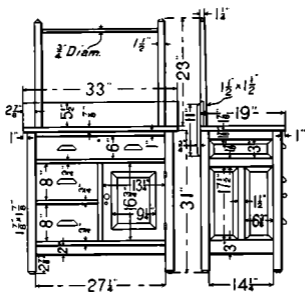

A washstand.

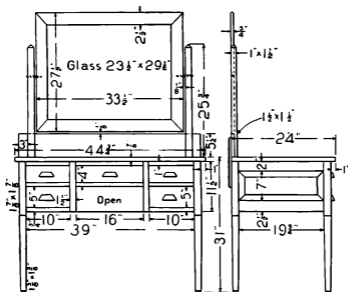

A dressing table.

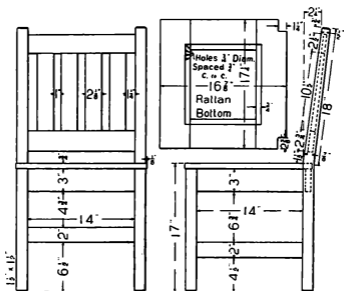

A common chair.

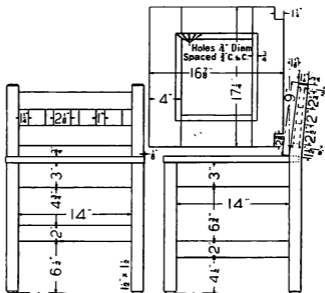

A lady's dressing chair.

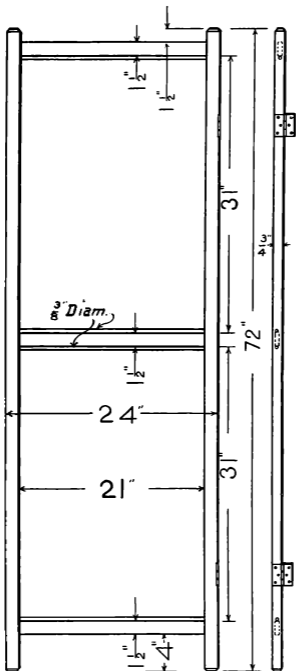

A leaf of a screen.

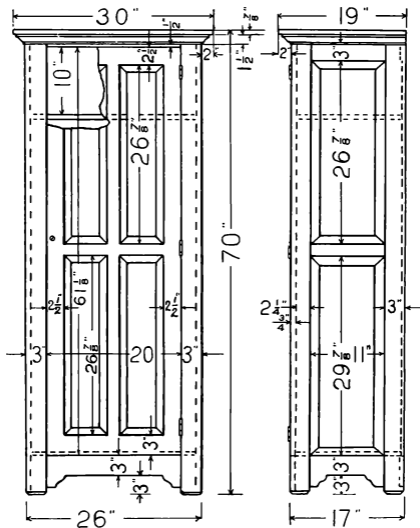

A wardrobe.

NOTE.—For a bed to accompany this set of furniture see design of iron bed in Bulletin No. 32, Bureau of Education. (P. S. A. T.)

INDUSTRIAL NOTES.

DESIGNS IN CURRENT NEEDLEWORK MAGAZINES.

The revival of the cross-stitch could not have a stronger encouragement than the particularly beautiful design given in the January number of the *Modern Priscilla*. The color scheme, however, is rather heavy and lacks the daintiness which should belong to any table linen. For this use different tones of a color, such as blue or yellow, for example, seem better adapted.

The present popularity of both the cross-stitch and the filet crochet makes it of interest to note that the design for the one is generally adaptable to the other, border designs in cross-stitch being often very good for filet insertion.

In the embroidery collars on page 7 of the January *Priscilla*, the designs for the decoration are all well planned, particularly No. 13-1-13 and No. 13-1-16; but the collars with revers (Nos. 13-1-10, 13-1-11, 13-1-12, and 13-1-17) could be much improved in shape. The construction of any article should always be of primary importance.

In No. 13-1-10, the many points give an uncomfortable look to the whole; the very sharp points of No. 13-1-11 are out of harmony with the curve, and the revers of the other two have an ungraceful relation with the collar part.

The centerpiece on page 8, as well as the embroideries on page 9 and the crochet on page 10, are quite attractive.

The designs on page 14 are commonplace with the exception of the bag, No. 13-1-14, which is well planned and very attractive.

The Battenberg lace on page 19 is a beautiful piece of work. Some of the motifs given here could be

rearranged for a candle shade to be worked in abaca braid and fiber or for a hat brim in the same medium.

The designs for the doilies on page 20 are acceptable with the exception of No. 13-1-17, in which the arrangement of the flower stems is poor; the edge, however, is quite pleasing and with a rearrangement of the stems the whole might be good.

In the "Fancy Work Album" of the *Paris Journal* for December the washstand set on the cover shows very poor design in ornamentation and also in the shape of the long doilies, the latter being very ungraceful.

The articles on page 1 are well planned, but the book cover and picture frame would be improved if the straight border line were continued along the back edge of the former and made to enclose the opening for the picture in the latter. The book-cover leaves a feeling of incompleteness as it is, and the picture frame needs the line to set off the picture from the frame.

The decoration of a picture frame should always be subordinate to the picture itself, and on this account should not be too ornate or heavy, or crowd upon the space allotted to the picture. This frame observes these points and for that reason is the best of those offered in this number.

Of the articles on page 3, Nos. 1 and 3 are the best in design; yet the color scheme would become tawdry if not very carefully handled and the style does not seem suitable for articles intended for utilitarian purposes.

The design for the bonbon box on page 4 is not so good as those

on page 8, the round ones there being particularly dainty. Here again (page 8) the style of ornament is poorly adapted to the use.

The chair cushion on page 4 and those on page 14 are generally poor, some of them especially so, and the embroidered square is exceedingly commonplace. The lampshade is acceptable, though not of great merit.

The lingerie squares, fig. 10 on page 5 and fig. 26, page 14, are well designed but the extravagant bows on the former detract from rather than add to its beauty.

The colored plates are all too elaborate to be suitable for school work, to say nothing of the designs. This is true also of the cushions offered on pages 12 and 13.

The candle shades on page 9 are very unattractive in shape.

The jewel boxes on page 10 are well designed with the exception of the landscape center, which is poor. The center of the liqueur tray on the same page is ungraceful.

The design for the thermometer holder on page 11 is very good.

Of the pincushions on pages 16 and 17, fig. 29 is very pleasing, fig. 7 not so good, and fig. 28 poor. The scraggly fringe adds nothing whatever to its beauty.

The chemise on page 9 is too ornate to be in good taste for underwear, especially for a young girl.—S. C. J.

o

On December 8, 1912, the Sorsogon provincial corn demonstration was held in Sorsogon, Sorsogon. The demonstration consisted of many features both entertaining and instructive. The day opened with a civic parade in which were floats of the provincial government, municipal government, provincial school, and municipal school. The provincial float was in the form of Old King Corn seated upon a throne and scattering grains of corn over the province from the large corn-

copa which he was holding. The next most interesting float was the municipal school's float which consisted of an enormous ear of corn guarded by a number of schoolboys who were dressed in blue jeans and straw hats. Each boy was carrying an ear or stalk of corn.

During the morning the provincial governor and the president of the town of Sorsogon spoke to the assembled crowd. The demonstration booths were constructed around a central octagonal booth which contained different sections devoted to "information," "seed selection and seed testing," "planting," "cultivation," "harvesting," "preparation of corn meal," and "corn machinery." In booths from which the foods were served 10,000 people were given samples of properly prepared corn foods. It was the largest gathering of people that had ever taken place in the town of Sorsogon. As amusement features, 1,600 corn pins made from grains of corn were distributed, and five different people were given ₱1 each and permitted to wander through the crowd with instructions that the peso was to be given to the first one who asked, "Have you the peso corn prize?" Every one was intensely interested and this served to add interest to the occasion.

The people were also very much interested in the booth where corn machinery was demonstrated. The following quotation from the report is given:

"In these two booths, shellers, mills, and hand cultivators were shown. The cultivators attracted much attention. These were shown in actual use on a corn field and any number of farmers tried them. A number of cultivators and mills could have been sold easily."

The good accomplished by this one demonstration was manifested in the immediate action taken by the provincial board to secure a quantity of seed corn for general distribution.

THE PROGRESS OF AGRICULTURAL
TRAINING IN DENMARK.

Denmark has recently been cited as an example of a nation which has found itself agriculturally. Military exploitation and the persistence in the growing of a single crop so impoverished the country that the land no longer furnished the people bread, and an exodus of the young and vigorous was the inevitable result. Wise men in the kingdom saw the danger, the aid of the government was enlisted and the financial resources of the Kingdom were diverted from the support of militarism to the restoration of the fertility of the soil. One of the first reforms was a breaking up of the old feudal system of land tenure, thereby making it possible for a Dane to own his land in fee simple. The great estates were broken up into small holdings, and the people being encouraged to engage in agriculture, the government set about creating markets for the products, with such success that Denmark is to-day one of the leading agricultural countries of Europe, and its dairy products are more highly esteemed in London than are the best British products.

But the Danish government did more than make it possible for the individual to own a bit of land in his own right and open up markets for his products. It established schools where the young are taught the secrets of agriculture, it sent experts everywhere to teach farmers the latest methods, showed them how to standardize their products, and prepared the way for the spirit of coöperation which has revolutionized the entire country.

Scientific experts furnished by the Danish government show the individual farmer how to rotate his crops to the best advantage. But this is by no means the end of governmental aid and supervision. It provides a chance for every worthy man. An agricultural laborer in

Denmark who has worked on a farm for five years, who is poor, and who has a character so good that two reputable members of his commune will certify to it, may obtain from one of the government credit banks a loan of about ₣3,164 in our money. He obtains this solely on his character and ability and not by any material security he can offer. With this money he may purchase a farm of from 3½ to 12 acres.

o

BATAC CORN DEMONSTRATION.

On December 16, 1912, a corn demonstration was held at Batac, Ilocos Norte. The demonstration was well attended and it was estimated that 2,000 people were present throughout the day. Of the many corn foods served, fried mush seemed to be the most popular. The demonstration was carried on in specially prepared booths under the charge of girls who cooked and served the foods.

In the afternoon a basket-ball game between the girls of the Batac Farm School and the Laoag Primary School was played. In one room of the farm school building, an industrial exhibit was arranged.

o

On November 30, 1912, a large corn demonstration was held at Laoag, Ilocos Norte. The following corn foods were prepared and served: Hominy, mush, fried mush, hoe cake, and johnny cake. In addition to the serving of corn foods, the grinding of meal, the testing of seeds, and the proper selection of corn were demonstrated. The corn demonstration began with a parade led by the constabulary and police in which were many floats and decorated carriages. It is estimated that 3,000 people were served corn foods. This is the second of the successful corn demonstrations held in Ilocos Norte.

HOME INDUSTRIES IN SWITZERLAND.

The recent industrial exhibit of the Bureau of Education, held during the Philippine Carnival, has served again to call the attention of the public to the industrial policy of the Bureau and the efforts which are being made to promote certain household industries throughout the Philippines. This problem is by no means original here; in many countries the long established home industries constitute an important item in the general welfare of the people and the revenues of the government.

In Switzerland, the home industries have been developed upon a larger scale than in most other countries; the products of embroidered articles alone constitute an important industry. Inasmuch as the Philippine Government, through the Bureau of Education, the School of Household Industries, and the Sales Agency, is giving special attention to the extension of needlework, the facts presented herewith, taken from consular and customs reports on Switzerland, are very significant.

Switzerland has an area of 15,976 square miles; the island of Luzon has an area of 40,969. The population of Switzerland is, in round numbers, 3,600,000; the population of Luzon is about 3,800,000. Switzerland, with about two-fifths the area of Luzon, supports nearly as many people.

By referring to the customs reports of the two countries some interesting comparisons are shown. The imports of Switzerland in 1910 were ₱661,549,000, while those of the Philippine Islands were but ₱64,123,000. This is less than one-tenth of Switzerland's total imports. The exports from Switzerland in 1910 were ₱461,606,000 and the exports from the Philippines during the same year amounted to ₱79,773,000, or about seventeen-

hundredths of the total of Switzerland's exports.

The itemized statement of the exports of Switzerland shows that during the year 1910 embroideries to the value of ₱78,901,532 were exported. Of this amount ₱1,808,760 is given as the value of the embroidered handkerchiefs exported. These figures show that Switzerland's exports of embroideries alone lack but ₱872,000 of amounting to as much as the entire exports of the Philippine Islands during the year 1910.

The embroideries exported from Switzerland reached all parts of the world. The reports of the Collector of Customs for the Philippine Islands show that in 1911 the Philippines imported from Switzerland embroideries to the value of ₱149,216, and that in 1912 embroideries to the value of ₱159,656 were imported from the same country.—R. B. R.

o

The first corn demonstration in the province of Oriental Negros was held in Dumaguete, November 25, 1912.

The young ladies of the domestic science department of the provincial school and a number of municipal teachers trained under the direction of the teachers of domestic science, prepared and served the different dishes of corn to the vast crowd that at all hours surrounded the booths. The demonstrators were neatly dressed in white aprons and caps and made a good impression upon all present.

Although numerous showers fell throughout the day, the attendance was good and much interest was shown in all lines of the demonstration. It is estimated that over 6,000 visited the booths and that about 2,000 tasted one or more of the dishes prepared from corn.

Six different methods of preparing corn were demonstrated and corn recipes, printed in the local dialect and neatly bound in pamphlet form, were distributed, free to all.

The corn exhibit and information booth attracted many people. Selected corn was displayed so as to show the proper manner to preserve seed corn. A germinating box with germinated seeds along with the ears from which the seeds were selected drew much attention. A modern plow, corn sheller, and corn mill were on display and their use demonstrated at frequent intervals.

A number of boys of the provincial school dressed as fat and lean clowns wearing the placards "I eat corn" and "I eat rice" took the part of a band and furnished much amusement during the day for the crowd.

Great interest has been shown from the beginning by the provincial and municipal officials and they have been of material assistance in making the demonstration a success.

Although corn is now the principal food of the people of this province it is felt that much good was accomplished. The interest shown by the crowds attending indicated that information for the betterment of local conditions will be spread by this means throughout the province.

Division Circular No. 84, series 1912, "District Corn Exhibit" makes provision for a series of corn exhibits within the division of Albay.

The division superintendent of schools for Sorsogon reports that the use of tobacco has been effective in killing the worms on the corn. He also suggests that the tobacco water must be strong, but care must be exercised to see that it is not strong enough to kill the plants.

Another of Albay's successful corn demonstrations was held at Guinobatan, Albay, on November 29 and 30, 1912. A very attractive four-page folder containing the program was prepared and distributed.

A corn demonstration was held at Bangued, Abra, on December 7, 1912. Hominy, dodol, fried mush, corn muffins, and corn bread were prepared and served to the people in attendance.

The following should be noted in connection with the drawings for nito baskets on page 458 of the December CRAFTSMAN:

In Plates XII and XIII "Full size" has reference to the blueprint working drawings which may be obtained on application to the Director of Education. These drawings show the baskets in full size and have proved to be of much assistance to workers.

In color scheme 1, Plate XII, the best effect is obtained by substituting "dark brown" for "red," and vice versa.

PHILIPPINE EXHIBIT IN THE U. S. NATIONAL MUSEUM.

An exhibition of the work done in the Philippine Islands schools, under the direction of the Bureau of Education of the Islands, has been set up temporarily in the southeast gallery of the old building of the National Museum, and will be open to the public several weeks. Its main object is to demonstrate the wealth of native material in the Philippines available for industrial use, and that the Bureau of Education is teaching the natives to use their own valuable resources.

The education is mainly along practical lines, especial stress being laid on the native industries and the utilization of native-grown materials. New industries are being developed

which will make use of new and hitherto unemployed native raw materials. In the schools only the most practical and salable objects are made. Although formerly the natives had several arts and industries of their own they were not always managed on a practical basis; materials were imported to manufacture articles and textiles which could have been made of local material and supplies, and which are, in many cases, far superior to the materials formerly used. Great credit is due the Americans for teaching the Filipinos how to employ home products for the manufacture of articles with both a local and foreign commercial value. This applies not only to textiles made from the fibers of Philippine plants, but also to baskets, which are constructed from rattan, bamboo, pineapple, and several other fibers and barks. There are on exhibition many fine specimens of cloth, embroidery, basketry, etc., made according to native designs and those suggested by the American teachers.

Among the industries taught in the Philippine schools are carpentry, cabinet making, basketry, straw braiding and hat making, sandal and slipper making, weaving, embroidery, etc. Household economy and domestic science are featured

in the schools and a large School of Household Industries has been established at Manila. The course in housekeeping is a comprehensive one, ranging from the primary through the high school grades, and designed not to revolutionize the ideas and methods in Filipino homes, but gradually to better them where opportunity permits.

In comparison to the per capita cost for scholars in the United States, the Filipino students cost the local government a little over one-tenth the expense incurred in the United States. The exhibit, showing the fine work done by the Bureau of Education, is all the more significant when it is remembered that the United States Congress makes no appropriation for the Philippines, and in 1910 the revenues were \$36,736,450.

An American scholar who has traveled extensively and studied the problem of social conditions is said to have remarked to President Taft that our Government was "doing the most interesting and most promising piece of original work in education now in progress anywhere in the world." This is readily accorded when the exhibit is examined and the wonderful results are realized.—
Smithsonian Press Statement.

BUREAU OF EDUCATION PUBLICATIONS.

(Abbreviated List.)

BULLETINS:

5. Notes on the Treatment of Smallpox.
10. Government in the United States. Prepared for use in the Philippine Public Schools.
24. Outline of Year's Course in Botany and Key to the Families of Vascular Plants in the Philippine Islands.
81. School and Home Gardening.
32. Courses in Mechanical and Free-hand Drawing, for Use in Trade and Intermediate Schools.
36. Philippine Hats. (Supply limited.)
34. Lace Making and Embroidery.
35. Housekeeping and Household Arts—A Manual for Work with the Girls in the Elementary Schools of the Philippine Islands.
37. School Buildings and Grounds.
38. School Buildings—Plans, Specifications and Bills of Materials.
39. A Manual of Free-hand Drawing for Philippine Primary Schools. (In course of preparation.)
40. Athletic Handbook for the Philippine Public Schools.
41. Service Manual of the Bureau of Education.
44. Libraries for Philippine Public Schools.
45. The School of Household Industries.
46. The Industrial Museum, Library and Exhibits of the Bureau of Education. (In course of preparation.)
47. Good Manners and Right Conduct for Primary Grades. (In course of preparation.)
48. A Course in Civics. (In course of preparation.)
49. Philippine Industrial Fibers. (In course of preparation.)

BULLETINS—Continued.

50. Arbor Day and School Holidays. (In course of preparation.)

CIVICO-EDUCATIONAL LECTURES:

1. The Rights and Duties of Citizens of the Philippines. (Supply limited.)
2. The Prevention of Diseases. (Supply limited.)
3. Rice. (Supply limited.)
4. Diseases of Animals. (Supply limited.)
5. Coconut Beetles. (Supply limited.)
6. The Housing of the Public Schools. (Supply limited.)
7. Coconuts.
8. Corn.

THE TEACHERS' ASSEMBLY HERALD:

- Volumes I, II, III and IV. (Supply exhausted.)
Volume V, 1912. (Supply limited.)
Volume VI, 1913. (Now current.)

TEXTBOOKS:

- Commercial Geography: the Materials of Commerce for the Philippines.
Economic Conditions in the Philippines. (In course of preparation.)
Supplementary Problems for Trade Schools and Trade Classes. (In course of preparation.)

THE PHILIPPINE CRAFTSMAN:

- Volume I. (Now current.)

MISCELLANEOUS:

- Woodworking, a Manual of Elementary Carpentry for Philippine Public Schools.
A Statement of Organization, Aims, and Conditions of Service in the Bureau of Education.
A Talk on Health Conditions in the Philippines.

